



April 2011

Product Specification

Industrial Rugged Metal

1.8" SATA II SLC SSD

-HERMES Series-

Doc-No: 100-xR8SF-JASL-1V1



*This document is for information use only and is **subject to change without prior notice**. APRO Co., Ltd. assumes no responsibility for any errors that may appear in this document, nor for incidental or consequential damages resulting from the furnishing, performance or use of this material. No part of this document may be reproduced, transmitted, transcribed, stored in a retrievable manner or translated into any language or computer language, in any form or by any means, electronic, mechanical, magnetic, optical, chemical, manual or otherwise, without the prior written consent of an officer of APRO Co., Ltd.*

All parts of the APRO documentation are protected by copyright law and all rights are reserved.

APRO and the APRO logo are registered trademarks of APRO Co., Ltd.

Product names mentioned herein are for identification purposes only and may be trademarks and/or registered trademarks of their respective companies.

© 2011 APRO Corporation. All rights reserved.

Revision History

Revision	Description	Date
1.0	Initial Release	2010/11/10
1.1	Table 9: Pin Assignments revised	2011/4/20

CONTENTS

- 1. INTRODUCTION..... - 1 -
 - 1.1. SCOPE - 2 -
 - 1.2. SYSTEM FEATURES..... - 2 -
 - 1.3. FLASH MANAGEMENT TECHNOLOGY - STATIC WEAR LEVELING - 2 -
- 2. PRODUCT SPECIFICATIONS - 3 -
 - 2.1. SYSTEM ENVIRONMENTAL SPECIFICATIONS - 3 -
 - 2.2. SYSTEM POWER REQUIREMENTS - 3 -
 - 2.3. SYSTEM PERFORMANCE - 3 -
 - 2.4. SYSTEM RELIABILITY - 4 -
 - 2.5. PHYSICAL SPECIFICATIONS - 4 -
 - 2.6. CONFORMAL COATING - 6 -
 - 2.7. CAPACITY SPECIFICATIONS - 6 -
- 3. INTERFACE DESCRIPTION..... - 7 -
 - 3.1. INDUSTRIAL RUGGED METAL 1.8” SATA II SLC SSD INTERFACE..... - 7 -
 - 3.2. PIN ASSIGNMENTS..... - 8 -
- 4. ELECTRICAL SPECIFICATION - 9 -
 - 4.1. DEVICE ELECTRICAL CHARACTERISTICS..... - 9 -
- 5. FUNCTIONAL DESCRIPTION - 10 -
 - 5.1. ATA COMMANDS - 10 -
- APPENDIX A. ORDERING INFORMATION - 11 -
 - 1. PART NUMBER LIST: - 11 -
 - 2. PART NUMBER DECODER:..... - 11 -
- APPENDIX B. LIMITED WARRANTY - 12 -

List of Tables

TABLE 1: ENVIRONMENTAL SPECIFICATION	- 3 -
TABLE 2: POWER REQUIREMENT	- 3 -
TABLE 3: SYSTEM PERFORMANCES	- 3 -
TABLE 4: IOPS (I/O ACCESS TIME PER SECOND) TEST PERFORMANCES.....	- 4 -
TABLE 5: SYSTEM RELIABILITY.....	- 4 -
TABLE 6: PHYSICAL SPECIFICATIONS.....	- 4 -
TABLE 7: CARD CONFIGURATION VS. SAMSUNG NAND SLC PART NUMBER.....	- 6 -
TABLE 8: DEVICE PARAMETERS.....	- 6 -
TABLE 9: PIN ASSIGNMENTS.....	- 8 -
TABLE 10: ABSOLUTE MAXIMUM RATINGS	- 9 -
TABLE 11: RECOMMENDED POWER SUPPLY OPERATION CONDITIONS	- 9 -
TABLE 12: ATA COMMANDS SUPPORTED.....	- 10 -

List of Figures

FIGURE 1: INDUSTRIAL 1.8” SATA II SLC SSD HERMES SERIES CONTROLLER BLOCK DIAGRAM	- 1 -
FIGURE 2: RUGGED METAL 1.8” SATA II SLC SSD DIMENSION.....	- 5 -
FIGURE 3 :THE FRONT VIEW OF 1.8” SATA II SLC SSD	- 7 -

1. Introduction

APRO Industrial Rugged Metal 1.8" SATA II SLC SSD – HERMES Series provide high capacity flash memory Solid State Drive (SSD) that electrically complies with Serial ATA 2.6 (SATA) standard. APRO Industrial Rugged Metal 1.8" SATA II SLC SSD – HERMES Series support SATA Gen-II (3.0 GB/s) with high performance. The main used flash memories are Samsung SLC-NAND type flash memory chips. The available disk capacities are 8GB, 16GB, 32GB and 64GB. The operating temperature grade is optional for commercial level 0°C ~ 70°C and wide temperature level -40°C ~ +85°C. The data transfer performance by sustained read is up to 184.2 MB/sec, and sustained write is up to 153.3 MB/sec.

The APRO Industrial Rugged Metal 1.8" SATA II SLC SSD products provide a high level interface to the host computer. This interface allows a host computer to issue commands to the 1.8" SATA SSD to read or write blocks of memory. Each sector is protected by a powerful 8 bits or 15 bits Error Correcting Code (ECC). APRO Industrial Rugged Metal 1.8" SATA II SLC SSD HERMES Series intelligent controller manages interface protocols, data storage and retrieval as well as ECC, defect handling and diagnostics, power management and clock control.

Figure 1 shows a block diagram of the used high tech Industrial Rugged Metal 1.8" SATA II SLC SSD controller.

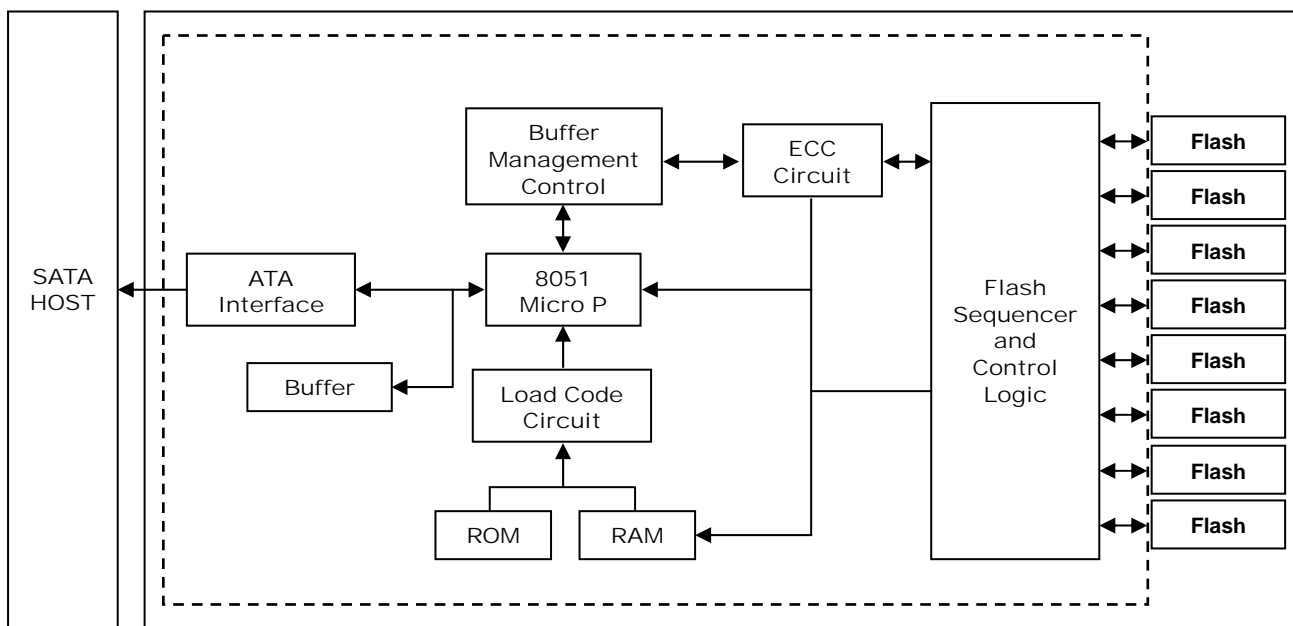

Figure 1: Industrial 1.8" SATA II SLC SSD HERMES Series controller block diagram

1.1. *Scope*

This document describes the features and specifications and installation guide of APRO's Industrial Rugged Metal 1.8" SATA II SLC SSDs – HERMES Series. In the appendix, there provides order information, warranty policy, RMA/DOA procedure for the most convenient reference.

1.2. *System Features*

- SLC-NAND type flash technology
- Standard 1.8" SATA II SLC SSD form-factor
- SATA 7-pin (data) + 15-pin (power connector) host Interface
- Extremely Rugged Metal casing to endure harsh environments
- SATA 1.0a and SATA 2.6 specification compliance
- SMART (Self-Monitoring, Analysis and Reporting Technology) function supported.
- Non-volatile memory and no moving parts
- Standard grade capacity from 8GB up to 64GB
- Industrial grade capacity from 8GB up to 64GB
- Performance up to 184.2 MB/sec
- Automatic 8 bits or 15 bits Error Correcting Code (ECC) error correction and retry capabilities
- +5 V $\pm 10\%$ operation
- MTBF > 3,000,000 hours.
- Vibration : 15G, compliance to MIL-STD-810F
- Shock : 1,500G, compliance to MIL-STD-810F
- Working well in critical environment
- Very high performance, very low power consumption
- Low weight, Noiseless

1.3. *Flash Management Technology - Static Wear Leveling*

In order to gain the best management for flash memory, APRO Industrial 1.8" SATA II SLC SSD HERMES Series supports Static Wear Leveling technology to manage the Flash system. The life of flash memory is limited; the management is to increase the life of the flash product.

A static wear-leveling algorithm evenly distributes data over an entire Flash cell array and searches for the least used physical blocks. The identified low cycled sectors are used to write the data to those locations. If blocks are empty, the write occurs normally. If blocks contain static data, it moves that data to a more heavily used location before it moves the newly written data. The static wear leveling maximizes effective endurance Flash array compared to no wear leveling or dynamic wear leveling.

2. Product Specifications

For all the following specifications, values are defined at ambient temperature and nominal supply voltage unless otherwise stated.

2.1. System Environmental Specifications

Table 1: Environmental Specification

APRO Industrial Rugged Metal 1.8" SATA II SLC SSD		Commercial Grade	Industrial Grade
HERMES Series		SR8SF0xxG-JACSC	WR8SF0xxG-JAISI
Temperature	Operating:	0°C ~ 70°C	-40°C ~ +85°C
	Non-operating:	-20°C ~ +80°C	-50°C ~ +95°C
Humidity	Operating & Non-operating:	10% ~ 95% non-condensing	
Vibration	Operating & Non-operating:	15G, compliance to MIL-STD-810F	
Shock	Operating & Non-operating:	1,500G, compliance to MIL-STD-810F	

2.2. System Power Requirements

Table 2: Power Requirement

APRO Industrial Rugged Metal 1.8" SATA II SSD		Standard Grade	Industrial Grade
HERMES Series		SR8SF0xxG-JACSC	WR8SF0xxG-JAISI
DC Input Voltage (VCC) 100mV max. ripple(p-p)		5V±10%	
+5V Current (Maximum average value)	Reading Mode :	280mA (max.)	
	Writing Mode :	340mA (max.)	
	Idle Mode :	150mA (max.)	

2.3. System Performance

Table 3: System Performances

Flash IC		Samsung SLC Flash IC			
Data Transfer Mode supporting		Serial ATA Gen-II (3.0Gb/s = 380MB/s)			
Maximum Performance	Capacity	8GB	16GB	32GB	64GB
	Sequential Read (MB/s)	184.2	143.0	180.5	180.5
	Sequential Write (MB/s)	107.8	106.7	153.1	153.3
Maximum QD 32	4K Random Read (MB/s)	17.75	17.77	21.54	18.03
	4K Random Write (MB/s)	3.49	3.71	2.87	2.85
Random Access Time		0.2	0.2	0.2	0.2
The number of Flash IC		8	8	8	8

Table 4: IOPS (I/O access time Per Second) Test Performances

Flash IC		Samsung SLC Flash IC			
I/O Per Second		4K Data Size Transfer / QD32 Test / AHCI Mode			
Maximum Performance	Capacity	8GB	16GB	32GB	64GB
	Random Read IOPS	4,679	4,594	4,399	4,396
	Random Write IOPS	511	785	592	592
	Sequential Read IOPS	5,366	8,019	4,970	4,957
	Sequential Write IOPS	6,840	6,487	4,853	4,832
The number of Flash IC		8	8	8	8

Note:

(1). All values quoted are typically at 25°C and nominal supply voltage.

(2). Testing of the Industrial Rugged Metal 1.8" SATA II SLC SSD maximum performance was performed under the following platform:

- Computer with AMD 3.0GHz processor
- Windows XP Professional operating system

(3). Above performance values are for reference only and the performance could be different from various systems configurations.

2.4. System Reliability

Table 5: System Reliability

MTBF	>3,000,000 hours
Wear-leveling Algorithms	Static Wear Leveling
Bad Blocks Management	Supportive
ECC Technology	8 bits or 15 bits Error Connection Code
Endurance	<ul style="list-style-type: none"> ● Unlimited Read Cycles ● Greater than 2,000,000 cycles Logically contributed by Wear-leveling and advanced bad sector management
Data Retention	10 years

2.5. Physical Specifications

Refer to Table 6 and see Figure 2 for Industrial Rugged Metal 1.8" SATA II SLC SSD HERMES Series physical specifications and dimensions.

Table 6: Physical Specifications

Length:	59.90 mm / 2.36 in
Width:	69.80 mm / 2.75 in
Thickness:	9.50 mm / 0.37 in
Weight:	55.00 g / 1.94 oz

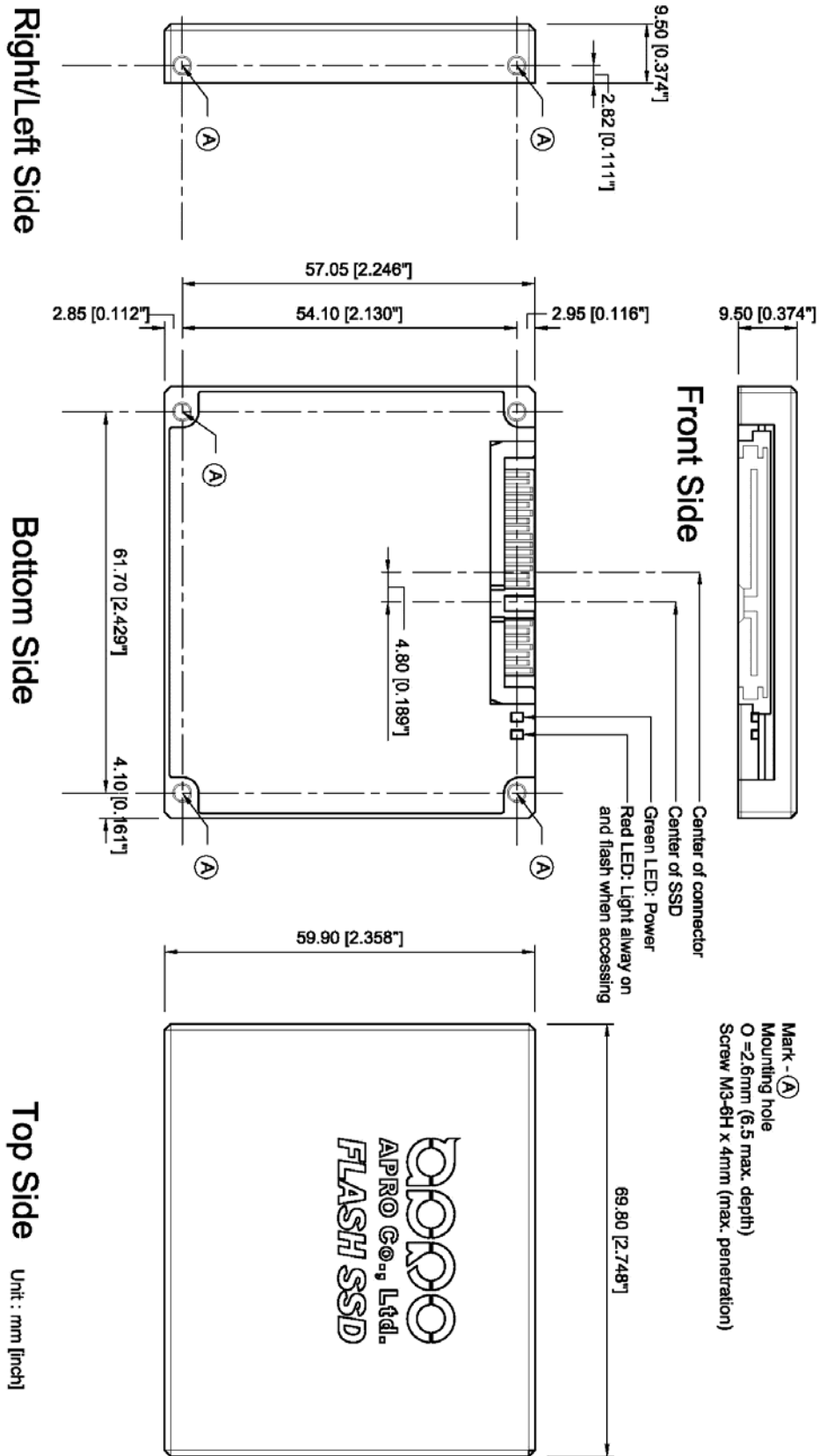

Figure 2: Rugged Metal 1.8" SATA II SLC SSD Dimension

2.6. Conformal coating

Conformal coating is a protective, dielectric coating designed to conform to the surface of an assembled printed circuit board. Commonly used conformal coatings include silicone, acrylic, urethane and epoxy. APRO applies only silicone on APRO storages products upon requested especially by customers. The type of silicone coating features good thermal shock resistance due to flexibility. It is also easy to apply and repair.

Conformal coating offers protection of circuitry from moisture, fungus, dust and corrosion caused by extreme environments. It also prevents damage from those Flash storages handling during construction, installation and use, and reduces mechanical stress on components and protects from thermal shock. The greatest advantage of conformal coating is to allow greater component density due to increased dielectric strength between conductors.

APRO uses MIL-I-46058C silicon conformal coating.

2.7. Capacity Specifications

APRO Industrial Rugged Metal 1.8" SATA II SLC SSDs have built-in Samsung SLC -NAND Type Flash memory chips. The Table 7 shows the part number of applied Samsung Flash memory chips for each card.

Table 7: Card Configuration vs. Samsung NAND SLC part number

Card capacity	Samsung SLC flash memory part number * Q'TY
8GB	K9F8G08U0M (8Gb) or equal * 8
16GB	K9WAG08U0M (16Gb) or equal * 8
32GB	K9WBG08U1M (32Gb) or equal * 8
64GB	K9NCG08U5M (64Gb) or equal * 8

The table 8 shows the specific capacity for the various models and the default number of heads, sectors/track and cylinders.

Table 8: Device Parameters

Unformatted Capacity	Default Cylinder	Default Head	Default Sector	LBA
8GB	14,645	16	63	14,761,984
16GB	16,383	16	63	29,523,968
32GB	16,383	16	63	59,047,936
64GB	16,383	16	63	118,095,872

3. Interface Description

3.1. Industrial Rugged Metal 1.8" SATA II SLC SSD interface

APRO Industrial Rugged Metal 1.8" SATA II SLC SSD comes with 7 pins + 15 pins Serial ATA connector.



Figure 3 :The front view of 1.8" SATA II SLC SSD

3.2. Pin Assignments

There are total of 7 pins in the signal segment and 15 pins in the power segment. The pin assignments are listed in below table 9.

Table 9: Pin Assignments

Name	Type	Description
S1	GND	
S2	A+	Differential Signal Pair A
S3	A-	
S4	GND	
S5	B-	Differential Signal Pair B
S6	B+	
S7	GND	
Key and Spacing separate signal and power segments		
P1	NC	NC
P2	NC	NC
P3	NC	NC
P4	GND	
P5	GND	
P6	GND	
P7	V5	5V Power, Pre-Charge
P8	V5	5V Power
P9	V5	5V Power
P10	GND	
P11	DAS/DSS	Device Activity Signal / Disable Staggered Spin up
P12	GND	
P13	NC	NC
P14	NC	NC
P15	NC	NC

Notes:

1. All pins are in a signal row with a 1.27 mm (0.050" pitch).
2. The commands on the mating sequence in forward table apply to the case of backplane blind mate connector only. In this case, the mating sequences are:
 - (1) The pre-charge power pins and other ground pins.
 - (2) The signal pins and the rest of the power pins.

4. Electrical Specification

4.1. Device Electrical Characteristics

Table 10: Absolute Maximum Ratings

Parameter	Symbol	Condition	Min	Max	Unit
Analog power supply	AV_{DDH}		-0.5	6	V
Digital I/O power supply	DV_{DD}		-0.5	6	V
Digital I/O input voltage	$V_{I(D)}$		-0.4	$DV_{DD}+0.4$	V
Storage temperature	$T_{STORAGE}$		-55	140	°C

Table 11: Recommended Power Supply Operation Conditions

Parameter	Symbol	Condition	Min	Typical	Max	Unit
DC Power Supply	V_{DD}		-0.3		+5.5	V
Input voltage	V_{IN}		-0.3		+5.5	V
Output voltage	V_{OUT}		-0.3		+3.8	
Operating Temperature	T_A	Standard	0		+70	°C
		Industrial	-40		+85	°C
Storage Temperature	T_{ST}	Standard	-20		+80	°C
		Industrial	-50		+95	°C

5. Functional Description

5.1. ATA Commands

The commands support ATA/ATAPI-6 commands; certain obsolesced commands are also supported. The supported commands are listed in Table 12.

Table 12: ATA Commands Supported

Command	Code	Support	Ext
Check Power Mode	E5H	Yes	Yes
Download Microcode	92H	Yes	Yes
Flush Cache	E7H	Yes	Yes
Identify Device	ECH	Yes	Yes
Idle	E3H	Yes	Yes
Idle immediate	E1H	Yes	Yes
Initialize Device Parameters	91H	Yes	Yes
Read Multiple	C4H	Yes	Yes
Read Sector(s)	20H	Yes	Yes
Read Verify Sector	40H	Yes	Yes
Read DMA	C8H	Yes	Yes
Recalibrate	10H	Yes	Yes
Set Features	EFH	Yes	Yes
Set Multiple Mode	C6H	Yes	Yes
Set Sleep Mode	E6H	Yes	Yes
SMART	B0H	Yes	Yes
Standby	E2H	Yes	Yes
Standby Immediate	E0H	Yes	Yes
Security Set Password	F1H	Yes	Yes
Security Unlock	F2H	Yes	Yes
Security Erase Prepare	F3H	Yes	Yes
Security Erase Unit	F4H	Yes	Yes
Security Freeze Lock	F5H	Yes	Yes
Security Disable Password	F6H	Yes	Yes
Write Multiple	C5H	Yes	Yes
Write Sector	30H	Yes	Yes
Write DMA	CAH	Yes	Yes

Appendix A. Ordering Information

1. Part Number List:

◆ Industrial Rugged Metal 1.8" SATA II SLC SSD – HERMES Series

Product Picture	Grade	Standard grade (0°C ~ 70°C)	Industrial Grade (-40°C ~ +85°C)
	8GB	SR8SF008G-JACSC	WR8SF008G-JAISI
	16GB	SR8SF016G-JACSC	WR8SF016G-JAISI
	32GB	SR8SF032G-JACSC	WR8SF032G-JAISI
	64GB	SR8SF064G-JACSC	WR8SF064G-JAISI

2. Part Number Decoder:

X1 X2 X3 X4 X5 X6 X7 X8 X9 – X11 X12 X13 X14 X15 / C

X1 : Grade

S: Standard Grade – operating temp. 0° C ~ 70 ° C

W: Industrial Grade – operating temp. -40° C ~ +85 ° C

X2 : The material of case

R : Rugged Metal Casing

X3 X4 X5 : Product category

8SF : 1.8" SATA II SSD

X6 X7 X8 X9 : Capacity

008G: 8GB **032G:** 32GB

016G: 16GB **064G:** 64GB

X11 : Controller

J : JMicron (HERMES Series)

X12 : Controller version

A,B,C.....

X13 : Controller Grade

C : Commercial grade

I : Industrial grade

X14 : Flash IC

S : Samsung SLC-NAND Flash IC

X15 : Flash IC grade / Type

C : Commercial grade

I : Industrial grade

C : Reserved for specific requirement

C : Conformal-coating

Appendix B. Limited Warranty

APRO warrants your Industrial Rugged Metal 1.8" SATA II SLC SSD against defects in material and workmanship for the life of the drive. The warranty is void in the case of misuse, accident, alteration, improper installation, misapplication or the result of unauthorized service or repair. The implied warranties of merchantability and fitness for a particular purpose, and all other warranties, expressed or implied, except as set forth in this warranty, shall not apply to the products delivered. In no event shall APRO be liable for any lost profits, lost savings or other incidental or consequential damages arising out of the use of or inability to use this product.

BEFORE RETURNING PRODUCT, A RETURN MATERIAL AUTHORIZATION (RMA) MUST BE OBTAINED FROM APRO.

Product shall be returned to APRO with shipping prepaid. If the product fails to conform based on customers' purchasing orders, APRO will reimburse customers for the transportation charges incurred.

Warranty period:

- SR8SF0xxG-JACSC 3 years
- WR8SF0xxG-JAISI 5 years



The warranty period is able to extend. Please contact APRO and/or Your APRO distributors for more information.