



December 2010

Product Specification

Industrial SLC CFast Card

-HERMES Series-

Doc-No: 100-XPCFAJB-01V0

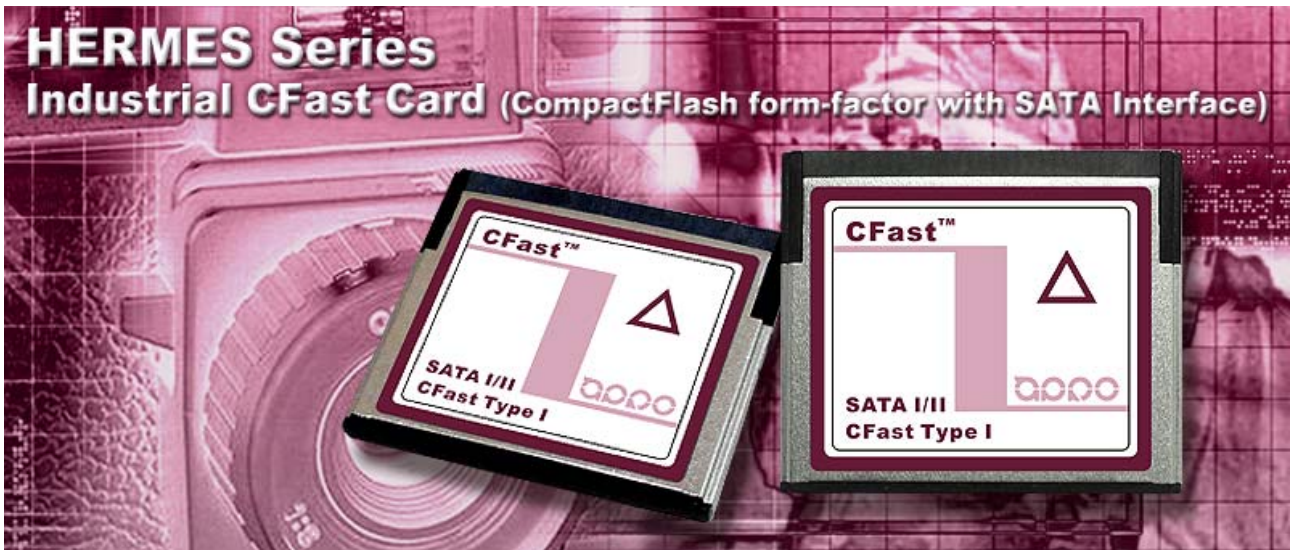

This document is for information use only and is subject to change without prior notice. APRO Co., Ltd. assumes no responsibility for any errors that may appear in this document, nor for incidental or consequential damages resulting from the furnishing, performance or use of this material. No part of this document may be reproduced, transmitted, transcribed, stored in a retrievable manner or translated into any language or computer language, in any form or by any means, electronic, mechanical, magnetic, optical, chemical, manual or otherwise, without the prior written consent of an officer of APRO Co., Ltd.

All parts of the APRO documentation are protected by copyright law and all rights are reserved.

The CFA logo and CFast are trademarks of the CompactFlash Association.

APRO and the APRO logo are registered trademarks of APRO Co., Ltd.

Product names mentioned herein are for identification purposes only and may be trademarks and/or registered trademarks of their respective companies.

© 2010 APRO Corporation. All rights reserved.

Revision History

Revision	Description	Date
01V0	<i>Preliminary version</i>	<i>2010/3/11</i>
	<i>Table 6: Flash memory chips part no. updated</i>	
	<i>General Correction</i>	<i>2010/9/24</i>
	<i>Table 4: MTBF life time updated</i>	
	<i>General Correction</i>	<i>2010/12/13</i>

CONTENTS

1. INTRODUCTION	- 1 -
1.1. Scope.....	- 2 -
1.2. System Features.....	- 2 -
1.3. Flash Management Technology - Static Wear Leveling	- 2 -
1.4. ECC Technology.....	- 3 -
1.5. Conformal Coating.....	- 3 -
1.6. Bad Block Management.....	- 4 -
2. PRODUCT SPECIFICATIONS	- 5 -
2.1. System Environmental Specifications.....	- 5 -
2.2. System Power Requirements.....	- 5 -
2.3. System Performance	- 5 -
2.4. System Reliability.....	- 6 -
2.5. Physical Specifications.....	- 6 -
2.6. Capacity Specifications	- 7 -
2.7. Pin Assignments.....	- 7 -
3. ELECTRICAL SPECIFICATION	- 9 -
3.1. Device Electrical Characteristics	- 9 -
4. ATA COMMAND REGISTER	- 10 -
4.1. ATA Commands.....	- 10 -
4.2. ATA Command Specification	- 11 -
4.3. Identify Device Information Default Value.....	- 11 -
4.4. S.M.A.R.T. Function (Self-Monitoring, Analysis, and Reporting Technology)	- 19 -
4.4.1. S.M.A.R.T. Read Data	- 19 -
4.4.2. S.M.A.R.T. ENABLE OPERATIONS.....	- 21 -
APPENDIX A ORDERING INFORMATION	- 22 -
APPENDIX B LIMITED WARRANTY	- 23 -

1. Introduction

APRO Industrial SLC CFast Card compliant to the CFast™ Specification 1.0 issued by CompactFlash Association (CFA), it breakthroughs the speed performance under traditional ATA/ATAPI specification. Integrating the CompactFlash card form factor and Serial ATA (SATA I & II) interface, the transfer speed is much higher than traditional CF Card while it keeps small form factor and rigid case as CF Card. APRO's HERMES Series Industrial CFast Card features with great portability and resistance against vibration. The sequential read speed is 105.6MB/sec and sequential write speed is 100.8MB for Single Level Cell (SLC) solution. The radical performance can widely meet customers' requirements, especially in embedded and industrial applications. Furthermore, APRO also provide Industrial 1.8" SATA II to CFast card Adapter to increase the application flexibility.

APRO's industrial SLC CFast Card supports optional standard grade operating temperature 0°C ~ 70°C and industrial grade temperature -40°C ~ +85°C. The capacities are available for 2GB, 4GB, 8GB and 16GB.

APRO's Industrial SLC CFast Card is suitable to handheld device embedded system, inventory recorder and particularly for serious environment monitor recorder system. Also, through APRO Industrial 1.8" SATA II to CFast card Adapter, APRO Industrial SLC CFast Card can be high speed booting SSD to varieties of IPC motherboards and PC structure system.

Figure 1 shows a block diagram of the used high tech CFast Card controller.

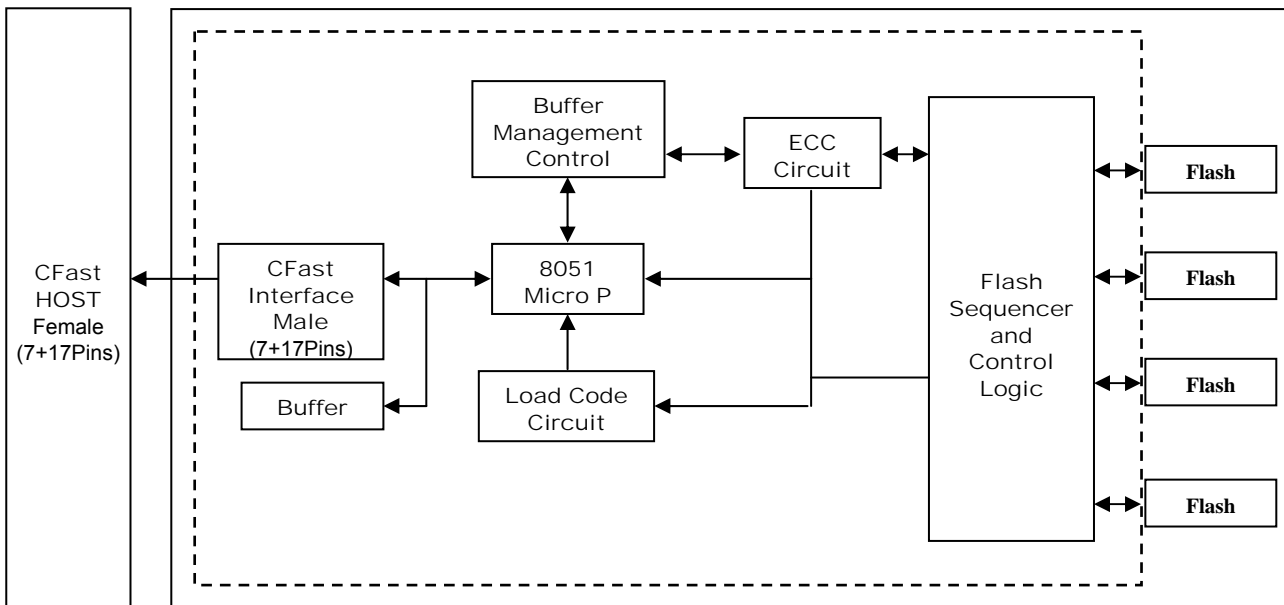

Figure 1: APRO Industrial SLC CFast Card – HERMES Series controller block diagram

1.1. Scope

This document describes the features and specifications and installation guide of APRO Industrial SLC CFast Card – HERMES Series. In the appendix, there provides order information for the most convenient reference.

1.2. System Features

- SLC-NAND type flash technology
- RoHS compliance
- Compliant CFast™ specification V1.0
- CompactFlash Card Type I form-factor
- 7-pin (data) + 17-pin (power) CFast Card connector
- SATA 1.0a and SATA 2.6 specification compliance
- Support SATA I/II (1.5/3.0Gbps) interface
- Data transfer compliant with ATA-7 / UDMA-5 and backward compatible
- Non-volatile memory and no moving parts
- Fixed Disk type
- Capacity from 2GB up to 16GB
- Performance up to 105.6 MB/sec
- Support BCH ECC 8 bits or 15 bits in 512 bytes
- Power supply supports +3.3V \pm 10%
- MTBF > 2,000,000 hours.
- Endurance cycles greater than 3,000,000 cycles
- Shock : 1,500G, compliance to MIL-STD-810F
- Vibration : 15G, compliance to MIL-STD-810F
- Critical environment is working well
- Very high performance, very low power consumption
- Low weight, Noiseless

1.3. Flash Management Technology - Static Wear Leveling

In order to gain the best management for flash memory, APRO Industrial SLC CFast Card – HERMES Series supports static wear -leveling technology to manage the Flash system. The life of flash memory is limited; the management is to increase the life of the flash product.

A static wear-leveling algorithm evenly distributes data over an entire Flash cell array and searches for the least used physical blocks. The identified low cycled sectors are used to write the data to those locations. If blocks are empty, the write occurs normally. If blocks contain static data, it moves that data to a more heavily used location before it moves the newly written data. The static wear leveling maximizes effective endurance Flash array compared to no wear leveling or dynamic wear leveling.

1.4. ECC Technology

Please refer to Figure 2. Figure 2 is a diagram illustrating an allocation method of a spare area in each page of a NAND flash memory, wherein the specific ECC algorithm utilizes a Bose, Chaudhuri and Hocquengham (BCH) ECC algorithm. When a BCH 8 ECC algorithm encodes the data in the NAND flash memory, the parity code generated in the encoding process may occupy 13 bytes of the spare area in each page. When a BCH 15 ECC algorithm encodes the data in the NAND flash memory, the parity code generated in the encoding process may occupy 25 bytes of the spare in each page.

When a BCH 8 algorithm decodes the data in the NAND flash memory, the data can be decoded correctly if the error bit happened in one sector (512 Bytes) is 8. When a BCH 15 algorithm decodes the data in the NAND flash memory, the data can be decoded correctly if the error bit happened in one sector is 15.

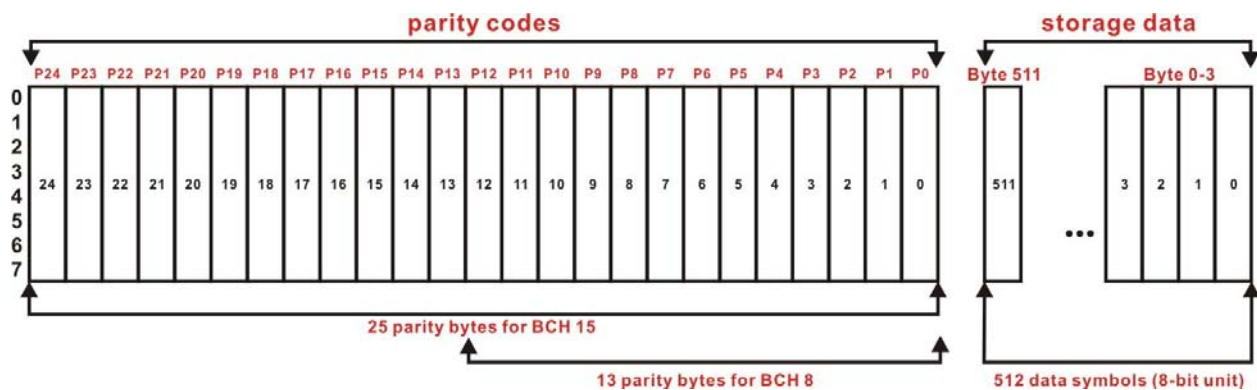

Figure 2: Allocation for ECC Algorithm BCH in NAND Flash

1.5. Conformal Coating

Conformal coating is a protective, dielectric coating designed to conform to the surface of an assembled printed circuit board. Commonly used conformal coatings include silicone, acrylic, urethane and epoxy. APRO applies only silicone on APRO storages products upon requested especially by customers. The type of silicone coating features good thermal shock resistance due to flexibility. It is also easy to apply and repair.

Conformal coating offers protection of circuitry from moisture, fungus, dust and corrosion caused by extreme environments. It also prevents damage from those Flash storages handling during construction, installation and use, and reduces mechanical stress on components and protects from thermal shock. The greatest advantage of conformal coating is to allow greater component density due to increased dielectric strength between conductors.

APRO apply MIL-I-46058C silicon conformal coating.

1.6. Bad Block Management

Bad blocks of NAND flash may accumulate up to 2% of entire number of blocks during its manufacturing process and during the flash operational usage.

A system must be able to recognize bad block(s) based on the original bad block information and create a bad block table to keep track of blocks that fail during use. The first block of NAND Flash (block 0) is guaranteed to be good. The bad block information is stored in the reservoir area that is located in the highest address region of the NAND flash. Once the bad blocks have been located, and the bad blocks be no longer accessed.

To locate the bad blocks on a brand new device, read out each block. Any block that is not all FFFFh in 1st sector of 1st or 2nd page in a spare area is a bad block. Although random bit errors may occur during use, this does not necessarily mean that a block is bad. Generally, a block should be marked as bad only when there is a problem or erase failure. This can be determined by doing a status read after erase/program operation. The flash memory is initialized by formatting the flash memory into a reserved area and user area.

In order to detect the initial bad blocks to handle run time bad blocks, APRO HERMES Series' SSD provides the Bad Block Management scheme. It remaps a bad block to one of the reserved blocks so that the data contained in one bad block is not lost and new data writes on a bad block is avoided.

2. Product Specifications

For all the following specifications, values are defined at ambient temperature and nominal supply voltage unless otherwise stated.

2.1. System Environmental Specifications

Table 1: Environmental Specification

APRO SLC CFast Card HERMES Series		Commercial Grade	Industrial Grade
		SPCFAXxxG-JBCSC	WPCFAXxxG-JBISI
Temperature	Operating:	0°C ~ +70°C	-40°C ~ +85°C
	Non-operating:	-20°C ~ +80°C	-50°C ~ +95°C
Humidity	Operating & Non-operating:	10% ~ 95% non-condensing	
Vibration	Operating & Non-operating:	15G, compliance to MIL-STD-810F	
Shock	Operating & Non-operating:	1,500G, compliance to MIL-STD-810F	
Altitude	Operating & Non-operating:	70,000 feet	

2.2. System Power Requirements

Table 2: Power Requirement

APRO SLC CFast Card HERMES Series		Standard Grade	Industrial Grade
		SPCFAXxxG-JBCSC	WPCFAXxxG-JBISI
DC Input Voltage (VCC)		3.3V±5%	
3.3V Current (Maximum average value)	Reading Mode :	280mA (max.)	
	Writing Mode :	330mA (max.)	
	Idle Mode :	170mA (max.)	

2.3. System Performance

Table 3: System Performances

Data Transfer Mode supporting		Serial ATA Gen-II (3.0Gb/s = 380MB/s)			
Average Access Time		0.1 ms (estimated)			
Maximum Performance	Capacity	2GB	4GB	8GB	16GB
	Sequential Read	100.4MB/s	104.7MB/s	104.8MB/s	105.6MB/s
	Sequential Write	98.6MB/s	100.2MB/s	100.1MB/s	100.8MB/s
The number of Flash IC		2pcs	4pcs	4pcs	4pcs

Note:

(1). All values quoted are typically at 25°C and nominal supply voltage.

(2). Testing of the APRO CFast Card maximum performance was performed under the following platform:

- Computer with AMD 3.0GHz processor
- Windows XP Professional operating system

2.4. System Reliability

Table 4: System Reliability

MTBF	>2,000,000 hours
Wear-leveling Algorithms	Static Wear-leveling
Bad Blocks Management	Supportive
ECC Technology	8 bits per 512 bytes in an ECC block
Endurance	Greater than 3,000,000 cycles Logically contributed by static wear-leveling and advanced bad sector management
Data Retention	10 years

2.5. Physical Specifications

Refer to Table 5 and see Figure 3 for **APRO Industrial SLC CFast Card – HERMES Series** physical dimensions

Table 5: Physical Specifications of Industrial CFast Card-HERMES Series

Length:	42.8 ± 0.10mm / 1.69 in
Width:	36.4 ± 0.15mm / 1.43 in
Thickness:	3.3 (3.6 max) + 0.1mm / 0.13 in
Weight:	10g / 0.4oz

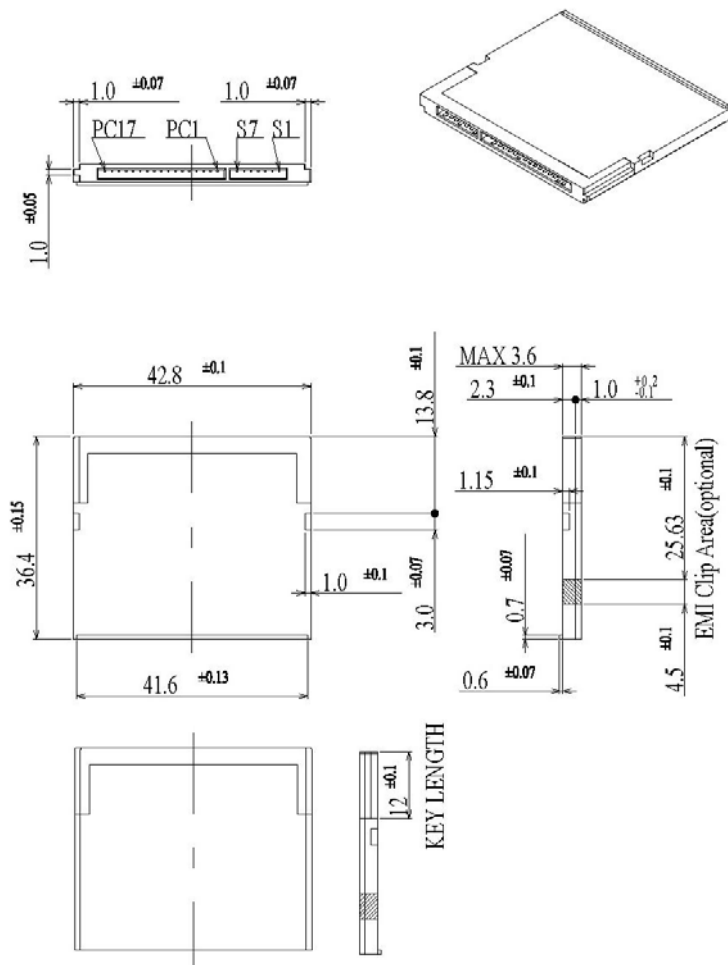

Figure 3: APRO Industrial SLC CFast Card – HERMES Series Dimension

2.6. Capacity Specifications

APRO Industrial SLC CFast Card – HERMES Series are built-in mainly Samsung SLC -NAND Type Flash memory chips. The Table 6 shows the equivalent part number of applied Samsung Flash memory chips for each card.

Table 6: Card Configuration vs. Samsung NAND SLC part number

Card capacity	Samsung SLC flash memory part number * Q'TY
2GB	K9F8G08U0M * 2 or equal * 2
4GB	K9F8G08U0M * 4 or equal * 4
8GB	K9KAG08U0M * 4 or equal * 4
16GB	K9WBG08U1M * 4 or equal * 4

The table 7 shows the specific capacity for the various models and the default number of heads, sectors/track and cylinders.

Table 7: Device Parameters

Unformatted Capacity	Cylinder	Head	Sector	LBA
2GB	3,876	16	63	3,910,762
4GB	7,785	16	63	7,847,280
8GB	15,498	16	63	15,621,984
16GB	31,272	16	63	31,522,816

2.7. Pin Assignments

Refer to Table 8 and see Figure 4 for APRO Industrial SLC CFast Card – HERMES Series pin assignments. There are total of 7 pins in the signal segment and 17 pins in the power segment. The pin assignments are listed in below table 8.



Figure 4: SATA 7-pin (data) + 17-pin (power)

**Table 8 - APRO Industrial SLC CFast Card – HERMES Series
SATA 7-pin (data) + 17-pin (power) Pin Assignments**

Name	Type	Description
7-pin Signal Segment		
S1	GND	
S2	A+	Differential Signal Pair A
S3	A-	
S4	GND	
S5	B-	Differential Signal Pair B
S6	B+	
S7	GND	
17-pin Power Segment		
PC1	CDI	Card Detect In
PC2	GND	Device GND
PC3	TBD1	N.C.
PC4	TBD2	N.C.
PC5	TBD3	N.C.
PC6	TBD4	N.C.
PC7	GND	Device GND
PC8	LED1	LED Output (PHYRDY signal)
PC9	LED2	LED Output (HDDA signal)
PC10	IO1	Reserved Input/Output
PC11	IO2	Reserved Input/Output
PC12	IO3	Reserved Input/Output
PC13	3.3V	Device Power (3.3V)
PC14	3.3V	Device Power (3.3V)
PC15	GND	Device Ground
PC16	GND	Device Ground
PC17	CDO	Card Detect Out

3. Electrical Specification

3.1. Device Electrical Characteristics

Table 9: Absolute Maximum Ratings

Parameter	Symbol	Condition	Min	Max	Unit
Analog power supply	AV _{DDH}		-0.5	3.6	V
Digital I/O power supply	DV _{DD}		-0.5	3.6	V
Digital I/O input voltage	V _{I(D)}		-0.4	DV _{DD} +0.4	V
Storage temperature	T _{STORAGE}		-55	+95	°C

Table 10: Recommended Power Supply Operation Conditions

Parameter	Symbol	Condition	Min	Typical	Max	Unit
DC Power Supply	V _{DD}		-0.3		+3.6	V
Input voltage	V _{IN}		-0.3		+3.6	V
Output voltage	V _{OUT}		-0.3		+3.8	V
Operating Temperature	T _A	Standard	0		+70	°C
		Industrial	-40		+85	°C
Storage Temperature	T _{ST}	Standard	-20		+80	°C
		Industrial	-55		+95	°C

4. ATA Command Register

4.1. ATA Commands

The commands supported ATA/ATAPI-7 commands; certain obsolesced commands are also supported. The supported commands are listed in Table 11.

Table 11: ATA Commands Supported

Command Name	Code	PARAMETERS USED					
		SC	SN	CY	DR	HD	FT
CHECK POWER MODE	E5h	-	-	-	O	-	-
IDENTIFY DEVICE	ECh	-	-	-	O	-	-
IDLE	E3h	O	-	-	O	-	-
IDLE IMMEDIATE	E1h	-	-	-	O	-	-
SMART	B0h	-	-	O	O	-	O
READ MULTIPLE	C4h	O	O	O	O	O	-
READ SECTOR(S)	20h or 21h	O	O	O	O	O	-
READ VERIFY SECTOR(S)	40h or 41h	O	O	O	O	O	-
READ DMA	C8h or C9h	O	O	O	O	O	-
SET FEATURES	EFh	O	-	-	O	-	O
SET MULTIPLE MODE	C6h	O	-	-	O	-	-
SLEEP	E6h	-	-	-	O	-	-
FLUSH CACHE	E7h	-	-	-	O	O	-
STANDBY	E2h	-	-	-	O	-	-
STANDBY IMMEDIATE	E0h	-	-	-	O	-	-
WRITE MULTIPLE	C5h	O	O	O	O	O	-
WRITE SECTOR(S)	30h or 31h	O	O	O	O	O	-
WRITE DMA	CAh or CBh	O	O	O	O	O	-
EXECUTE DIAGNOSTICS	90h	-	-	-	O	-	-
INITIALIZE DEVICE PARAMETERS	91h	O	-	-	O	O	-
SEEK	7xh	-	-	O	O	O	-
RECALIBRATE	10h	-	-	-	O	-	-
SECURITY DISABLE PASSWORD	F6h	-	-	-	O	-	-
SECURITY ERASE PREPARE	F3h	-	-	-	O	-	-
SECURITY ERASE UNIT	F4h	-	-	-	O	-	-
SECURITY FREEZE LOCK	F5h	-	-	-	O	-	-
SECURITY SET PASSWORD	F1h	-	-	-	O	-	-
SECURITY UNLOCK	F2h	-	-	-	O	-	-

Note:

O = Valid, - = Don't care

SC = Sector Count Register

SN = Sector Number Register

CY = Cylinder Low/High Register

DR = DEVICE SELECT Bit (DEVICE/HEAD Register Bit 4)

HD = HEAD SELECT Bit (DEVICE/HEAD Register Bit 3-0)

FT = Features Register

4.2. ATA Command Specification

Check Power Mode (E5h)

The host can use this command to determine the current power management mode.

Execute Diagnostics (90h)

This command performs the internal diagnostic tests implemented by the drive. See ERROR register for diagnostic codes.

Flush Cash (E7h)

This command is used by the host to request the device to flush de write cache. If there is data in the the write cache, the data shall be written to the media. The BSY bit shall remain set to one until all data has been successfully written or an error occurs.

Identify Device (ECh)

This commands read out 512Bytes of drive parameter information. Parameter Information consists of the arrangement and value as shown in the following table. This command enables the host to receive the Identify Drive Information from the device.

4.3. Identify Device Information Default Value

Table 12 - Identify Device Information Table

Word	Value	Description
0	0040h	General Configuration Bit 15 0=ATA device Bit 14:8 Retired Bit 7:6 Obsolete Bit 5:3 Retired Bit 2 Response incomplete Bit 1 Retired Bit 0 reserved
1	XXXXh	Number of logical cylinders
2	37C8h	Specific configuration
3	16	Number of logical heads
4-5	0000h	Retired
6	63	Number of logical sectors per logical track
7-9	0000h	Retired
10-19	20 ASCII characters	Serial number (ATA String)
20-21	0000h	Retired
22	003Fh	Obsolete
23-26	8 ASCII characters	Firmware revision(ATA String)
27-46	40 ASCII characters	Model number(ATA String)
47	8001h	15-8: 80 7-0: 00h Reserved 01h-FFh: Maximum number of sectors that shall be transferred per DRQ data block on READ/WRITE Multiple commands
48	4000h	Trusted Computing feature set options 15 shall be cleared to zero 14 shall be set to one 13:1 Reserved for the Trusted Computing Group 0 0 = Trusted Computing feature set is not supported
49	2F00h	Capabilities

Word	Value	Description
		15-14: Reserved for the IDENTIFY PACKET DEVICE command. 13: 1=Standby timer values as specified in this standard are supported 0: Standby timer values shall be managed by the device 12: Reserved for the IDENTIFY PACKET DEVICE command 11: 1=IORDY supported 0=IORDY may be disabled 10: 1=IORDY may be disabled 9: 1=LBA supported 8: 1=DMA supported. 7-0 Retired
50	4000h	Capabilities 15: Shell be cleared to zero 14: Shall be set to one 13:2 Reserved 1 Obsolete 0 0
51	0280h	Obsolete
52	0000h	Obsolete
53	0007h	15 Free-fall control Sensitivity 00h: Vendor's recommended setting 7: 3 Reserved 2: 1=the fields reported in word 88 are valid 1: 1=the fields reported in words (70:64) are valid 0: Obsolete
54	XXXXh	Number of current logical cylinders
55	XXXXh	Number of current logical heads
56	XXXXh	Number of current logical sectors per logical track
57-58	XXXXh	Current capacity in sectors
59	0001h	15:9 Reserved 8 0:Multiple sector setting is invalid 7:0 Current setting for number of logical sectors that shall be transferred per DRQ data block on READ/WRITE Multi commands
60-61	XXXXXXXXh	Total number of user address sectors(DWord)
62	0000h	Obsolete
63	0007h	Multi-word DMA transfer(Not support)
64	0003h	15-8 Reserved 7-0 PIO modes supported
65	0078h	Minimum Multiword DMA transfer cycle time per word 15-0 Cycle time in nanoseconds
66	0078h	Manufacturer's recommended Multiword DMA transfer cycle time per word 15-0 Cycle time in nanoseconds
67	0078h	Minimum PIO transfer cycle time without flow control 15-0 Cycle time in nanoseconds
68	0078h	Minimum PIO transfer cycle time with IORDY flow control 15-0 Cycle time in nanoseconds
69-74	0000h	Reserved
75	0000h	No DMA QUEUED command supports
76	0606h	Serial ATA Capabilities 15:11 Reserved for Serial ATA 10 1= Supports Phy Event Counters 9 1= Supports receipt of host initiated power management Requests 8 0= No Support native Command Queuing 7:3 Reserved for future SATA signaling speed grades 2 1=Supports SATA Gen2 Signaling Speed (3.0Gb/s) 1 1=Support SATA Gen1 Signaling Speed (1.5Gb/s) 0 Shall be cleared to zero
77	0000h	Reserved for Serial ATA
78	0000h	Serial ATA features supported

Product Specification

Word	Value	Description
		15:7 Reserved for Serial ATA 6 0=Device not supports Software Settings Preservation 5 Reserved for Serial ATA 4 0= Device not supports in-order data delivery 3 0= Device not supports initiating power management 2 0= Device not supports DMA Setup auto-activation 1 0= Device not supports non-zero buffer offsets 0 Shall be cleared to zero
79	0000h	Serial ATA feature enabled 15:7 Reserved for Serial ATA 6 0=Software Settings Preservation not enabled 5 0=Reserved for Serial ATA 4 0= In-order data delivery not enabled 3 0= Device initiated power management not enabled 2 0= DMA setup auto-activation not enabled 1 0= Non-zero buffer offsets not enabled 0 Shall be cleared to zero
80-81	01FE 0021h	ATA Version support (ATA8-ACS)
82	0069h	Command and feature sets supported 15 0 = Obsolete 14 0 = NOP Command not supported 13 0 = READ BUFFER Command not supported 12 0 = WRITE BUFFER Command not supported 11 0 = Obsolete 10 0 = Host Protected Area Feature Set not supported 9 0 = DEVICE RESET Command not supported 8 0 = SERVICE Interrupt not supported 7 0 = RELEASE Interrupt not supported 6 1 = Look-ahead supported 5 1 = Write Cache supported 4 0 = indicate that the PACKET feature set is not supported 3 1 = mandatory Power Management Feature Set supported 2 0 = Obsolete 1 0 = Security Mode Feature Set not supported 0 1 = SMART Feature Set supported
83	5000h	Command and feature sets supported 15 Shall be cleared to zero 14 Shall be set to one 13 0 = FLUSH CACHE EXT Command not supported 12 1 = mandatory FLUSH CACHE Command supported 11 0 = Device Configuration Overlay feature set not supported 10 0 = 48-Bit Address feature set not supported 9 0 = Automatic Acoustic Management feature set not supported 8 0 = SET MAX security extension not supported 7 0 = See Address Offset Reserved Area Boot, INCITS TR27:2001 6 0 = SET FEATURES subcommand not required to spin-up after power-up 5 0 = Power-Up in Standby feature set supported 4 0 = Removable Media Status Notification feature set not supported 3 0 = Advanced Power Management feature set not supported 2 0 = CFA feature set not supported 1 0 = READ/WRITE DMA QUEUED not supported 0 1 = DOWNLOAD MICROCODE Command supported
84	4000h	Command Set/Feature Supported Extension

Product Specification

Word	Value	Description
		15 Shall be cleared to zero 14 Shall be set to one 13-6 Reserved 5 0 = General Purpose Logging feature set not supported 4 Reserved 3 0 = Media Card Pass Through Command feature set not supported 2 0 = Media Serial Number not supported 1 0 = SMART self-test not supported 0 1 = SMART Error Logging not supported
85	0008	Command and feature sets supported or enabled 15 0 = Obsolete 14 0 = NOP Command not enabled 13 0 = READ BUFFER Command not enabled 12 0 = WRITE BUFFER Command not enabled 11 Obsolete 10 0 = Host Protected Area feature set not enabled 9 0 = DEVICE RESET Command not enabled 8 0 = SERVICE Interrupt not enabled 7 0 = RELEASE Interrupt not enabled 6 0 = Look-ahead not enabled 5 0 = Write Cache not enabled 4 Shall be cleared to zero to indicate that the PACKET Command feature set is not supported. 3 1 = Power Management Feature Set enabled 2 0 = Removable Media feature set not enabled 1 0 = Security Mode Feature Set not enabled 0 0 = SMART Feature Set not enabled
86	5000h	Command set/feature enabled 15-14 0 = Reserved 13 0 = FLUSH CACHE EXT Command not supported 12 1 = FLUSH CACHE Command supported 11 0 = Device Configuration Overlay not supported 10 0 = 48-Bit Address features set not supported 9 0 = Automatic Acoustic Management feature set not enabled 8 0 = SET MAX security extension not enabled by SET MAX SETPASSWORD 7 0 = Reserved 6 0 = SET FEATURES subcommand required to spin-up after power-up not enabled 5 0 = Power-Up in Standby feature set not enabled 4 0 = Obsolete 3 1 = Advanced Power Management feature set enabled 2 0 = CFA feature set not supported 1 0 = READ/WRITE DMA QUEUED Command not supported 0 1 = DOWNLOAD MICROCODE Command supported
87	4000h	Command and feature sets supported or enabled 15 Shall be cleared to zero 14 Shall be set to one 13 1 = IDLE IMMEDIATE with UNLOAD FEATURE supported 12 0 = Reserved for Technical Report, INCITS TR-37-2004 11 0 = Reserved for Technical Report, INCITS TR-37-2004 10:9 0 = Obsolete 8 0 = 64-Bit World Wide Name not supported 7 0 = WRITE DMA QUEUED FUA EXT Command not supported 6 0 = WRITE DMA FUA EXT and WRITE MULTIPLE FUA EXT commands not supported 5 0 = General Purpose Logging feature set not supported 4 0 = Obsolete 3 0 = Media Card Pass Through Command feature set not supported 2 0 = Media Serial Number is not valid 1 0 = SMART Self-Test not supported

Product Specification

Word	Value	Description
		0 0 = SMART Error-Logging not supported
88	X03Fh	Ultra DMA modes 15 Reserved 14 0 = Ultra DMA mode 6 is not supported 13 1= Ultra DMA mode 5 is selected 0= Ultra DMA mode 5 is not selected 12 1= Ultra DMA mode 4 is selected 0= Ultra DMA mode 4 is not selected 11 1= Ultra DMA mode 3 is selected 0= Ultra DMA mode 3 is not selected 10 1= Ultra DMA mode 2 is selected 0= Ultra DMA mode 2 is not selected 9 1= Ultra DMA mode 1 is selected 0= Ultra DMA mode 1 is not selected 8 1= Ultra DMA mode 0 is selected 0= Ultra DMA mode 0 is not selected 7 Reserved 6 0= Ultra DMA mode 6 is not supported 5 1= Ultra DMA mode 5 and below are supported 4 1= Ultra DMA mode 4 and below are supported 3 1= Ultra DMA mode 3 and below are supported 2 1= Ultra DMA mode 2 and below are supported 1 1= Ultra DMA mode 1 and below are supported 0 1= Ultra DMA mode 0 is supported
89	0000h	Time required for Normal Erase mode SECURITY ERASE UNIT command
90	0000h	Time required for Enhanced erase mode SECURITY ERASE UNIT command
91	0000h	Current advanced power management level value
92	0000h	Master Password Identifier
93	XXXXh	Hardware reset result
94	80FEh	Current automatic acoustic management value
		15:8 Vendor's recommended acoustic management value. 7:0 Current automatic acoustic management value.
95-126	0000h	Reserved
127	0000h	Obsolete
128	0000h	Security Status
		15:9 Reserved
		8 Security level 0 = high, 1 = Maximum
		7:6 Reserved
		5 1= Enhanced security erase supported
		4 1= Security count expired 3 0= Security frozen.
		2 0 = Security not locked
1 0= Security not enabled		
0 0= Security not supported		
129-159	0000h	Vendor specific
160	0000h	CFA power mode 1(Not support)
161-175	0000h	Reserved
176-205	0000h	Current media serial number
206-254	0000h	Reserved
255	XXXXh	Integrity word
		15:8 Check Sum
		7:0 Signature
Key: F/V = Fixed/ variable content		

Word	Value	Description
F= the content of the word is fixed and does not change. For removable media devices, these values may change when media is removed or changed. V= the content of the word is variable and may change depending on the state of the device or the command by the device. X= the content of the word may be fixed or variable.		

Idle (E3h)

This comment causes the device to set BSY, enter the Idle mode, clear BSY and generate an interrupt. If sector count is non-zero, the automatic power down mode is enabled. If the sector count is zero, the automatic power mode is disabled.

Idle Immediate (E1h)

This command causes the devices to set BSY, enter the Idle (Read) mode, clear BSY and generate an interrupt.

Initialize Device Parameters (91h)

This command enables the host to set the number of sectors per track and the number of tracks per heads.

Read Buffer (E4h)

The Read Buffer command enables the host to read a 512-byte block of data.

Read DMA (C8h)

Read data from sectors during Ultra DMA and Multiword DMA transfer. Use the Set Features command to specify the mode value. A sector count of zero requests 256 sectors.

Read DMA Ext (25h)

48-bit feature sent mandatory command. Read data from sectors during Ultra DMA and Multiword DMA transfer. Use the Set Features command to specify the mode value. A sector count of zero requests 65536 sectors.

Read FPDMA Queued (60h)

NCQ feature set mandatory 48-bit command. This command requests that data to be transferred from the device to the host.

Read Log Ext (2Fh)

General purpose logging feature set mandatory 48-bit command. This command requests that data to be transferred from the device to the host.

Log Address	Log Name	Feature	R/W	Access
00h	Log directory	N/A	RO	GPL
10h	NCQ Command Error	NCQ	RO	GPL

Read Multiple (C4h)

This command performs similarly to the Read Sectors command. Interrupts are not generated on each sector, but on the transfer of a block which contains the number of sectors defined by a Set Multiple command.

Read Multiple Ext (29h)

48-bit feature set mandatory command. This command performs similarly to the Read Sectors command. Interrupts are not generated on each sector, but on the transfer of a block which contains the number of sectors defined by a Set Multiple command.

Read Sector(s) (20h/21h)

This command reads 1 to 256 sectors as specified in the Sector Count register from sectors which is set by Sector number register. A sector count of 0 requests 256 sectors. The transfer beings specified in the Sector Number register.

Read Sector(s) Ext (24h)

48-bit feature set mandatory command. This command reads 1 to 65536 sectors as specified in the Sector Count register from sectors which is set by Sector number register. A sector count of zero requests 65536 sectors. The transfer beings specified in the Sector Number register.

Read Verity Sector(s) (40h/41h)

This command verifies one or more sectors on the drive by transferring data from the flash media to the data buffer in the drive and verifying that the ECC is correct. This command is identical to the Read Sectors command, except that DRQ is never set and no data is transferred to the host.

Read Verity Sector(s) Ext (42h)

48-bit feature set mandatory command. This command verifies one or more sectors on the drive by transferring data from the flash media to the data buffer in the drive and verifying that the ECC is correct. This command is identical to the Read Sectors command, except that DRQ is never set and no data is transferred to the host.

Recalibrate (10h)

The current drive performs no processing if it receives this command. It is supported for backward compatibility with previous devices.

Security Disable Password (F6h)

Disables any previously set user password and cancels the lock. The host transfers 512 bytes of data, as shown in the following table, to the drive. The transferred data contains a user or master password, which the drive compares with the saved password. If they match, the drive cancels the lock. The master password is still saved. It is re-enabled by issuing the SECURITY SET PASSWORD command to re-set a user password.

Security Freeze Lock (F5h)

Causes the drive to enter Frozen mode. Once this command has been executed, the following commands to update a lock result in the Aborted Command error:

- SECURITY SET PASSWORD
- SECURITY UNLOCK
- SECURITY DISABLE PASSWORD
- SECURITY ERASE PREPARE
- SECURITY ERASE UNIT

The drive exits from Frozen mode upon a power-off or hard reset. If the SECURITY FREEZE LOCK command is issued when the drive is placed in Frozen mode, the drive executes the command, staying in Frozen mode.

Security Set Password (F1h)

This command set user password or master password. The host outputs sector data with PIO data-out protocol to indicate the information defined in the following table.

Security Unlock (F2h)

The command disables LOCKED MODE of the device. This command transfers 512 bytes of data from the host with PIO data-out protocol. The following table defines the content of this information.

Seek (7xh)

This command is effectively a NOP command to the device although it does perform a range check.

Set Features (EFh)

This command set parameter to Features register and set driver's operation. For transfer mode, parameter is set to Sector Count register. This command is used by the host to establish or select certain features.

Table 13 - Feature registers Value and settable operating mode

Value	Function
02h	Enable write cache
03h	Set transfer mode based on value in Sector Count register
55h	Disable read look-ahead feature
82h	Disable write cache
AAh	Enable read look-ahead feature

Set Multiple Mode (C6h)

This command enables the device to perform READ MULTIPLE and WRITE MULTIPLE operations and establishes the block count for these commands.

Sleep (E6h)

This command causes the device to set BSY, enter the Sleep mode, clear BSY and generate in interrupt.

Smart Function Set (B0h)

Performs different processing required for predicting device failures, according to the subcommand specified in the Features register. If the Features register contains an unsupported value, the Aborted Command error is returned. If the SMART function is disabled, any subcommand other than SMART ENABLE OPERATIONS results in the Aborted Command error.

Code	Smart Subcommand
D0h	READ DATA
D1h	READ ATTRIBUTE THRESHOLDS
D2h	ENABLE/DISABLE ATTRIBUTE AUTOSAVE
D3h	SAVE ATTRIBUTE VALUES
D4h	EXECUTE OFF-LINE IMMEDIATE*
D5h	Reserved
D6h	Reserved

Code	Smart Subcommand
D8h	ENABLE OPERATIONS
D9h	DISABLE OPERATIONS
DAh	RETURN STATUS
DBh	ENABLE/DISABLE AUTO OFF-LINE*

4.4. S.M.A.R.T. Function (Self-Monitoring, Analysis, and Reporting Technology)

To perform different processing requires predicting device failures, according to the subcommand specified in the Features register.

If the Features register contains an unsupported value, the Aborted Command error is returned. If the SMART function is disabled, any subcommand other than SMART ENABLE OPERATIONS results in the Aborted Command error.

4.4.1. S.M.A.R.T. Read Data

Table 14: SMART Feature registers values

Value	Command
D0h	SMATR Read Data
D8h	SMART ENABLE OPERATIONS
D9h	SMART DISABLE OPERATIONS

Table 15: SMART command for inputs information

Register	7	6	5	4	3	2	1	0
Features	D0h							
Sector Count	Na							
LBA Low	Na							
LBA Mid	4Fh							
LBA High	C2h							
Device	Obs	Na	obs	DEV	Na	Na	Na	Na
Command	B0h							

Device register-

DEV shall specify the selected device.

Table 16: SMART command for normal outputs information

Register	7	6	5	4	3	2	1	0
Error	Na							
Sector Count	Na							
LBA Low	Na							
LBA Mid	Na							
LBA High	Na							
Device	Obs	Na	obs	DEV	Na	Na	Na	Na
Status	BSY	DRDY	DF	Na	DRQ	Na	Na	ERR

Device Register-

DEV shall indicate the selected device.

Status register-

BSY will be cleared to zero indicating command completion.

DRDY will be set to one. SMART enabled.

DF (Device Fault) will be cleared to zero.

DRQ shall be cleared to zero.

ERR shall be cleared to zero.

Table 17: ID of SMART data structure

ID(Hex)	Description
E9	ECC Fail Record
EA	Average Erase Count, Max Erase Count
EB	Good Block Count, System Block Count

ID: E9h

Table 18: Smart command for ECC fails record information

Byte	Function	Description
0	ECC fail number	When failure bit is bigger than “ECC Fail number”, this block will be marked as Bad Block.
1	Row address 3	Flash Block Address
2	Row address 2	Flash Block Address
3	Row address 1	Flash Block Address
4	Channel number of last ECC fail	NA
5	Bank number of last ECC fail	NA
6	Reserved	NA
7	Reserved	NA

ID: EAh

Table 19: Smart command for average/max erase count information

Byte	Function	Description
0	Average Erase Count (High Byte)	Average erase count of all blocks.
1	Average Erase Count	
2	Average Erase Count (Low Byte)	
3	Max Erase Count (High Byte)	Indicate a block which's erase count is the largest.
4	Max Erase Count	
5	Max Erase Count (Low Byte)	
6	Reserved	NA
7	Reserved	NA

When the Maximum erase count is 255 bigger than average erase count, the wear-leveling will be executed.

ID: EBh

Table 20: Smart command for good/system block count information

Byte	Function	Description
0	Good Block Count (High Byte)	Total used blocks of SSD
1	Good Block Count	
2	Good Block Count (Low Byte)	
3	System(Free) Block Count (High Byte)	Free block of SSD. Free block has to be bigger than

4	System(Free) Block Count (Low Byte)	20. When the free block count is less than 20, the SSD will be locked.
5	Reserved	NA
6	Reserved	NA
7	Reserved	NA

4.4.2. S.M.A.R.T. ENABLE OPERATIONS

Table 21: SMART Enable command for inputs information

Register	7	6	5	4	3	2	1	0
Features	D8h							
Sector Count	Na							
LBA Low	Na							
LBA Mid	4Fh							
LBA High	C2h							
Device	Obs	Na	obs	DEV	Na	Na	Na	Na
Command	B0h							

Device register-

DEV shall specify the selected device.

Table 22: SMART command for normal outputs information

Register	7	6	5	4	3	2	1	0
Error	Na							
Sector Count	Na							
LBA Low	Na							
LBA Mid	Na							
LBA High	Na							
Device	Obs	Na	obs	DEV	Na	Na	Na	Na
Status	BSY	DRDY	DF	Na	DRQ	Na	Na	ERR

Device Register-

DEV shall indicate the selected device.

Status register-

BSY will be cleared to zero indicating command completion.

DRDY will be set to one.

This command enables access to all SMART capabilities within device.

DF (Device Fault) will be cleared to zero.

DRQ shall be cleared to zero.

ERR shall be cleared to zero.

Appendix A Ordering Information

Part Number List:

◆ Operating temperature supports Standard grade 0°C ~ 70°C and Industrial grade -40°C ~ +85°

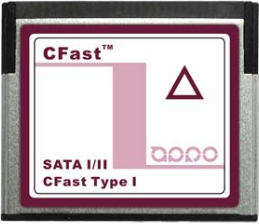
Product Picture	Grade	Standard grade (-10°C ~ 70°C)	Industrial Grade (-40°C ~ +85°C)
	2GB	SPCFA002G-JBCSC	WPCFA002G-JBISI
	4GB	SPCFA004G-JBCSC	WPCFA004G-JBISI
	8GB	SPCFA008G-JBCSC	WPCFA008G-JBISI
	16GB	SPCFA016G-JBCSC	WPCFA016G-JBISI

Part Number Decoder:

X1 X2 X3 X4 X5 X6 X7 X8 X9 — **X11 X12 X13 X14 X15** / **C**

X1 : Grade

S : Standard Grade – operating temp. 0° C ~ 70 ° C

W : Industrial Grade – operating temp. -40° C ~ +85 ° C

X13 : Controller grade

C : Commercial grade

I : Industrial grade

X2 : The material of case

P : Plastic frame kit

X14 : Flash IC

S : Samsung SLC-NAND Flash IC

X3 X4 X5 : Product category

CFA : CFast card

X15 : Flash IC grade / Type

C : Commercial grade

I : Industrial grade

X6 X7 X8 X9 : Capacity

002G: 2GB

004G: 4GB

008G: 8GB

016G: 16GB

C : Reserved for specific requirement

C : Conformal-coating

X11 : Controller

J : JMicron (HERMES Series)

X12 : Controller version

A, B, C.....

Appendix B Limited Warranty

APRO warrants your CFast Card against defects in material and workmanship for the life of the drive. The warranty is void in the case of misuse, accident, alteration, improper installation, misapplication or the result of unauthorized service or repair. The implied warranties of merchantability and fitness for a particular purpose, and all other warranties, expressed or implied, except as set forth in this warranty, shall not apply to the products delivered. In no event shall APRO be liable for any lost profits, lost savings or other incidental or consequential damages arising out of the use of, or inability to use, this product.

BEFORE RETURNING PRODUCT, A RETURN MATERIAL AUTHORIZATION (RMA) MUST BE OBTAINED FROM APRO.

Product shall be returned to APRO with shipping prepaid. If the product fails to conform based on customers' purchasing orders, APRO will reimburse customers for the transportation charges incurred.

Warranty Period:

- ***SPCFAxxxG-JBCSC*** ***3 year***
- ***WPCFAxxxG-JBISI*** ***5 year***



The warranty period is able to extend. Please contact with APRO and / or Your APRO distributor for more information.