

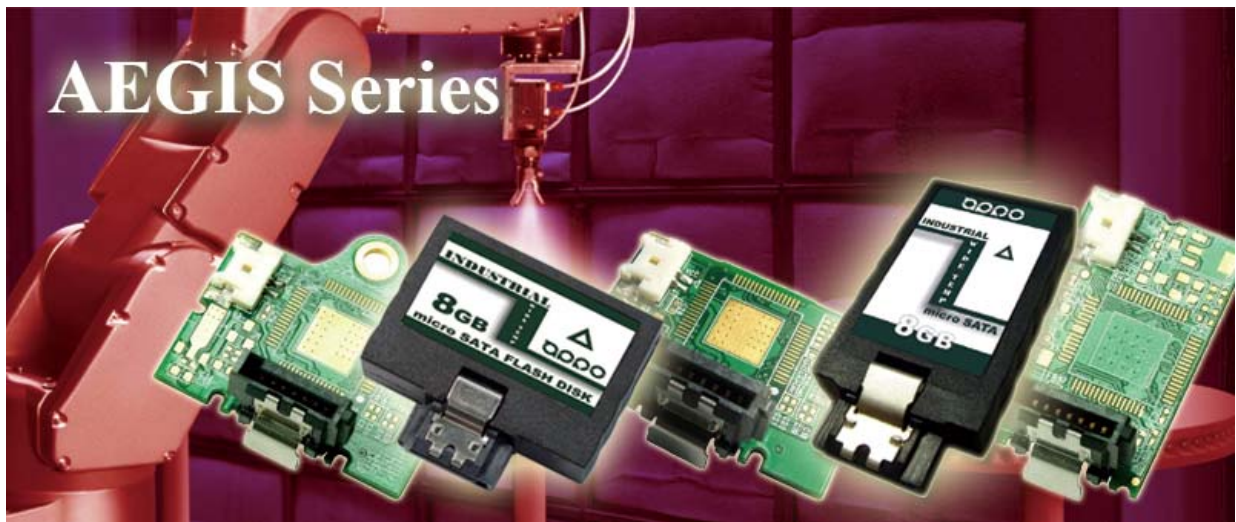

Nov. 2009

# Product Specification micro SATA Flash Disk - Aegis Series -

Doc-No: 100-MSFTA-01V2



*This document is for information use only and is subject to change without prior notice. APRO Co., Ltd. assumes no responsibility for any errors that may appear in this document, nor for incidental or consequential damages resulting from the furnishing, performance or use of this material. No part of this document may be reproduced, transmitted, transcribed, stored in a retrievable manner or translated into any language or computer language, in any form or by any means, electronic, mechanical, magnetic, optical, chemical, manual or otherwise, without the prior written consent of an officer of APRO Co., Ltd..*

*All parts of the APRO documentation are protected by copyright law and all rights are reserved.*

*APRO and the APRO logo are registered trademarks of APRO Co., Ltd.*

*Product names mentioned herein are for identification purposes only and may be trademarks and/or registered trademarks of their respective companies.*

*© 2008 APRO Corporation. All rights reserved.*

*Revision History*

<i>Rev.</i>	<i>Description</i>	<i>Update</i>
<i>01V1</i>	<i>Preliminary Version 1.0 —Initial released</i>	<i>2008/11/18</i>
<i>01V2</i>	<i>Add. VL Type ( Vertical low-profile form factor )</i>	<i>2009/9/29</i>
	<i>Add. HL Type ( Horizontal low-profile form factor )</i>	<i>2009/9/29</i>
	<i>Add. HO Type ( Horizontal low-profile form factor with mounting hole )</i>	<i>2009/9/29</i>
	<i>Cancel Leftward Type</i>	<i>2009/9/29</i>

**CONTENTS**

<b>1.</b>	<b>INTRODUCTION</b> .....	<b>3</b>
1.1.	SCOPE.....	3
1.2.	SYSTEM FEATURES .....	3
1.3.	SERIAL ATA SPECIFICATION & ATAPI STANDARD .....	4
1.4.	FLASH MANAGEMENT TECHNOLOGY.....	4
1.5.	SYSTEM BLOCK DIAGRAM.....	4
<b>2.</b>	<b>PRODUCT SPECIFICATIONS</b> .....	<b>5</b>
2.1.	SYSTEM ENVIRONMENTAL SPECIFICATIONS .....	5
2.2.	SYSTEM POWER REQUIREMENTS .....	5
2.3.	SYSTEM PERFORMANCE .....	5
2.4.	SYSTEM RELIABILITY.....	6
2.5.	PHYSICAL SPECIFICATIONS .....	6
2.6.	CAPACITY SPECIFICATIONS.....	9
<b>3.</b>	<b>GENERAL FEATURE SET</b> .....	<b>10</b>
3.1.	SATA I CONTROLLER.....	10
3.2.	WEAR-LEVELING .....	10
3.3.	ERROR DETECTION AND CORRECTION.....	10
3.4.	READ RECOVERY TECHNOLOGY .....	10
3.5.	AUTO POWER DOWN MODE.....	10
<b>4.</b>	<b>INTERFACE DESCRIPTION</b> .....	<b>11</b>
4.1.	PHYSICAL DESCRIPTION .....	11
4.2.	PIN ASSIGNMENTS .....	11

---

<b>5.</b>	<b><i>ELECTRICAL SPECIFICATION</i></b> .....	<b>12</b>
<b>5.1.</b>	<b><i>ABSOLUTE MAXIMUM RATING</i></b> .....	<b>12</b>
<b>5.2.</b>	<b><i>ATA I/O DC CHARACTERISTICS</i></b> .....	<b>12</b>
<b>6.</b>	<b><i>ATA/ATAPI COMMAND LIST</i></b> .....	<b>13</b>
<b>6.1.</b>	<b><i>DIRECTIONS</i></b> .....	<b>14</b>
<b>APPENDIX A.</b>	<b><i>ORDERING INFORMATION</i></b> .....	<b>15</b>
<b>APPENDIX B.</b>	<b><i>LIMITED WARRANTY</i></b> .....	<b>18</b>
<b>APPENDIX C.</b>	<b><i>AFTER SERVICE</i></b> .....	<b>19</b>

---

## 1. Introduction

APRO Industrial mSATA Flash Disk - Aegis series is an extremely compact design for SATA interfaces which follows Serial ATA 1.0a (1.5Hz) and compatible with ATAPI-5 specifications. They are mainly used Samsung NAND Type SLC Flash memory chip and managed by the serial ATA controller. The available mSATA Flash Disk capacities are 128MB, 256MB, 512MB, 1GB, 2GB, 4GB and 8GB. The operating temperature support commercial grade 0°C ~ +70°C (up to 8GB) and industrial grade -40°C ~ +85°C (up to 4GB). The data transfer performance supports sustain read up to 25.1MB per second, and sustain write up to 13.6MB per second.

The APRO Industrial mSATA Flash Disk - Aegis series products provide a high level interface to the host computer. This interface allows a host computer to issue commands to the Flash Disk to read or write blocks of memory, and the host addresses the card in 512 byte sectors. Each sector is protected by a powerful 8-bit Error Correcting Code (ECC).

With the great flexibility to meet different SATA interface locations in systems, APRO mSATA Flash Disk comes with optional form-factor in vertical type, leftwards and rightwards. And the power operating voltage supports 5V. Particularly it is built-in power pin as the 7<sup>th</sup> pin of 7pin header (w/fuse) or power input power cable (w/o fuse). They are ideal high performance of Flash storages for applications such like Digital Signage, Multimedia Car PC, Terminal Information Systems, Medical Equipments, Telecommunication and Enterprises Systems.

### 1.1. Scope

This document describes the features and specifications and installation guide of APRO's Industrial mSATA Flash Disk - Aegis series products. In the appendix, there provides order information, warranty policy, and RMA procedure for the most convenient reference.

### 1.2. System Features

- Serial ATA 1.0a Specification compliance
- Compatible with ATA-5 specification
- NAND type SLC flash technology
- Disk capacity from 128MB to 8GB
- Support standard / low-profile vertical & horizontal form-factor
- Data transfer mode supports Serial ATA I (1.5Gb/s)
- Performance up to 25.1MB/sec
- Automatic error correction and retry capabilities
- Performs data correction and data move to another block in case of the correctable error.
- Sudden Power Fail Tolerance
- Enables to reduce data loss in case of sudden power fail
- +5 V  $\pm$ 10%, optional built-in power pin as the 7<sup>th</sup> pin of 7pin header (w/fuse) or power input power cable (w/o fuse).
- MTBF > 1,000,000 hours.
- Very high performance, very low power consumption
- Low weight, Noiseless

### 1.3. Serial ATA Specification & ATAPI Standard

APRO Industrial mSATA Flash Disk - Aegis series supports Serial ATA 1.0a Specification and are fully compatible with the ATA/ATAPI-5 (ATA-66) standard.

### 1.4. Flash Management Technology

In order to gain the best management for flash memory, APRO Industrial mSATA Flash Disk - Aegis series supports an efficient and algorithms to manage the Flash system. The life of flash memory is limited; the management is to increase the life of the flash product. There are some blocks are reserved in flash memory and these blocks would not be used in normal operation. When host writes new file to flash memory, the flash controller will check the status field in the lookup table firstly and find out the available index which status is unused, less used & stale, or used & stale. Then it writes the new file into the block pointed by the index filed at the lookup table. All three statuses are available for data store. All three statuses are available for data store, and the priority for write operation is 1st. un-used; 2nd. Less used & stale; 3<sup>rd</sup>. Used & stale. When host updates the old file within the flash memory, the host will read the old file to system memory ahead. Then flash controller will update such file into the block after check the lookup table to find out the available blocks with the above three status then write the update data into the corresponding block and mark the previous block stale at the look up table.

### 1.5. System Block Diagram

Figure 1 shows the system block diagram of the used high tech Industrial ATA Flash controller and Serial ATA Bridge.

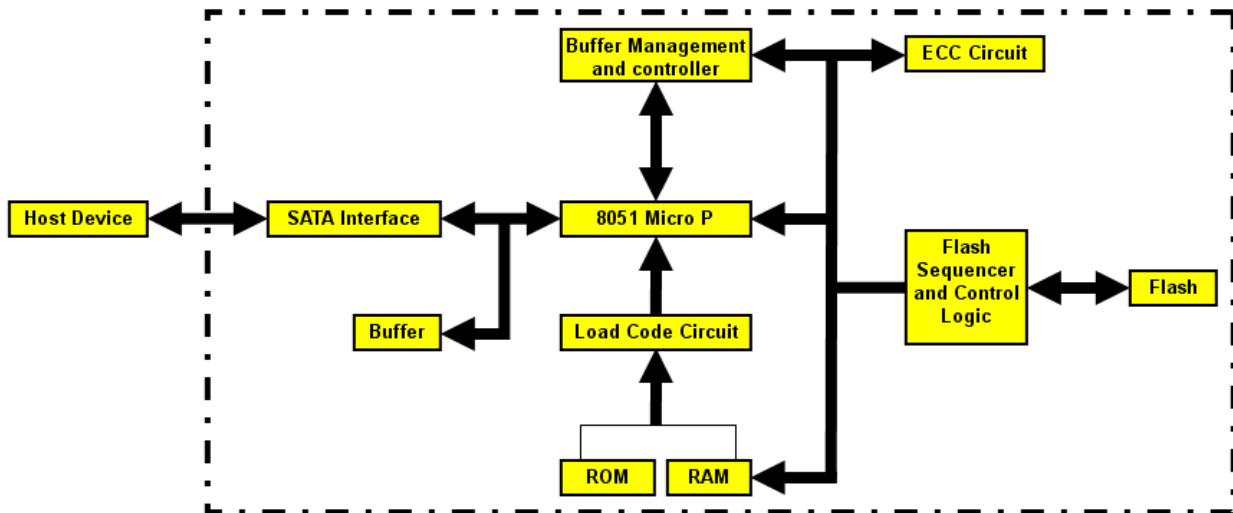

Figure 1- mSATA Flash Disk Block Diagram

## 2. Product Specifications

For all the following specifications, values are defined at ambient temperature and nominal supply voltage unless otherwise stated.

### 2.1. System Environmental Specifications

**Table 1: Environmental Specifications**

APRO Industrial mSATA Flash Disk Titans Series		
Temperature	Operating / Non-operating:	-40°C ~ +85°C / -50°C ~ +95°C
Humidity	Operating & Non-operating:	5% ~ 95% non-condensing
Vibration	Operating & Non-operating:	16G peak-to-peak maximum
Shock	Operating & Non-operating:	1,500 G maximum

### 2.2. System Power Requirements

**Table 2: Power Requirements**

APRO Industrial mSATA Flash Disk Titans Series	
Power Voltage :	5V±10%
Reading Mode :	155 mA (max.)
Writing Mode :	170 mA (max.)
Idle Mode :	105 mA (max.)

**Table 3 - Power Connector**

Pin No.	Connector
Pin 1	Vcc 5V
Pin 2	GND



**Figure 2 – Power Cable for mSATA Flash Disk**

### 2.3. System Performance

**Table 4 - System Performances**

Performance/Capacity	128MB	256MB	512MB	1GB	2GB	4GB	8GB
	MB/s	MB/s	MB/s	MB/s	MB/s	MB/s	MB/s
Random Access Time	1.1ms	1.1ms	0.8ms	0.8ms	0.8ms	1.1ms	1.0ms
Random Read	18,669	18,665	18,560	18,457	17,855	15,489	11,297
Random Write	2,817	2,736	2,963	3,113	3,168	3,414	3,604
Read	22,826	22,831	22,831	22,750	22,669	20,607	19,215
Write	7,727	7,413	7,962	7,819	8,099	6,949	8,521

**Note:**

1. All values quoted are typically at 25°C and nominal supply voltage.
2. Testing of the Industrial mSATA Flash Disk maximum performance was performed under the following



and dimensions.

**Table 6 - Physical Specifications**

	Length:	Width:	Height:	Weight:
<b>Vertical Type - Standard Form-factor(VS)</b>	39.2 mm	20.50 mm	8.0 mm (Housing thickness)	5.0g
<b>Vertical Type - Low Profile Form-factor(VL)</b>	22.8 mm	32.83 mm	8.0 mm (Housing thickness)	5.0g
<b>Horizontal Type - Standard Form-factor (HS)</b>	35.2 mm	18 mm	4.5 mm (CTL + PCB + Flash)	5.0g
<b>Horizontal Type - Low Profile Form-factor (HL)</b>	20.08 mm	30.0 mm	4.5 mm (CTL + PCB + Flash)	5.0g
<b>Horizontal Type - Low Profile w/ mounting hole (HO)</b>	28.8 mm	30 mm	4.5 mm (CTL + PCB + Flash)	5.0g

**Vertical Type - Standard Form-factor (VS)**

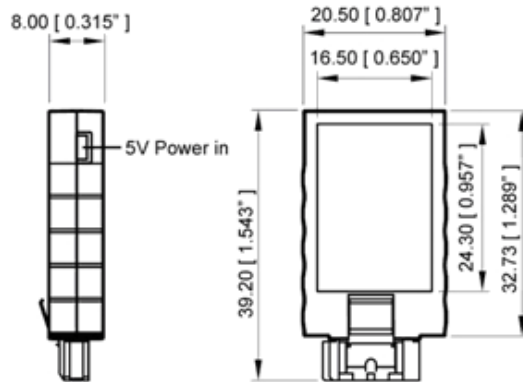

**Vertical Type - Low Profile Form-factor (VL)**

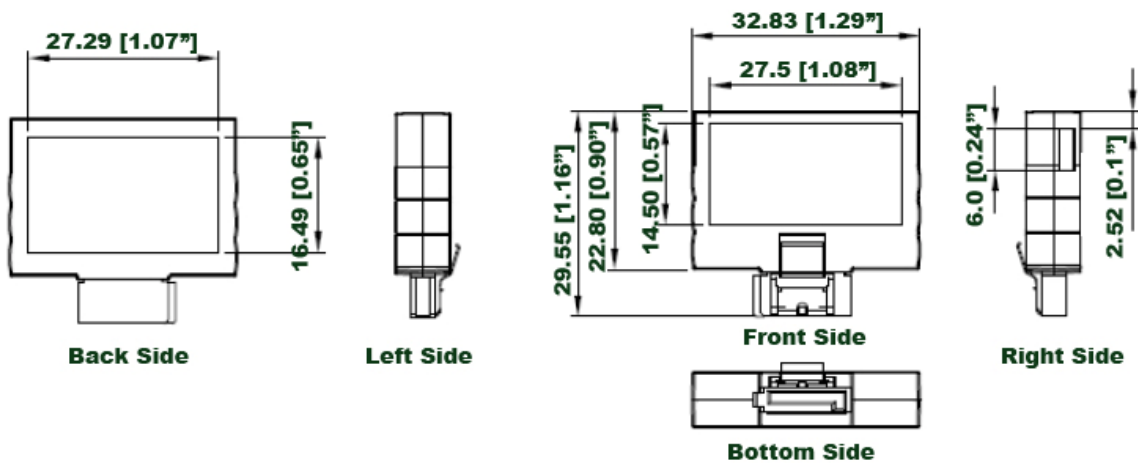

**Horizontal Type - Standard Form-factor (HS)**

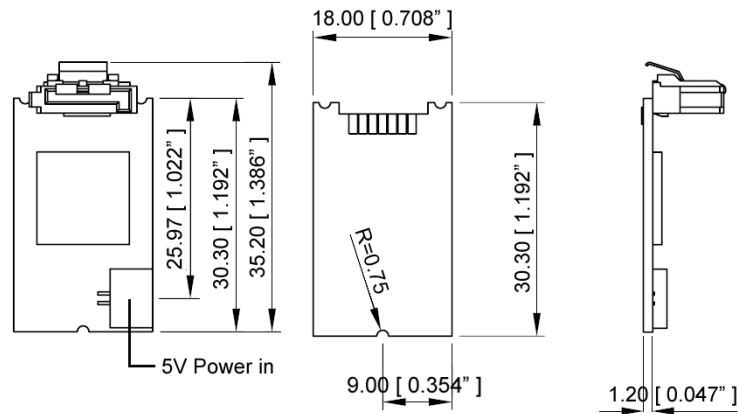

**Horizontal Type - Low Profile Form-factor (HL)**

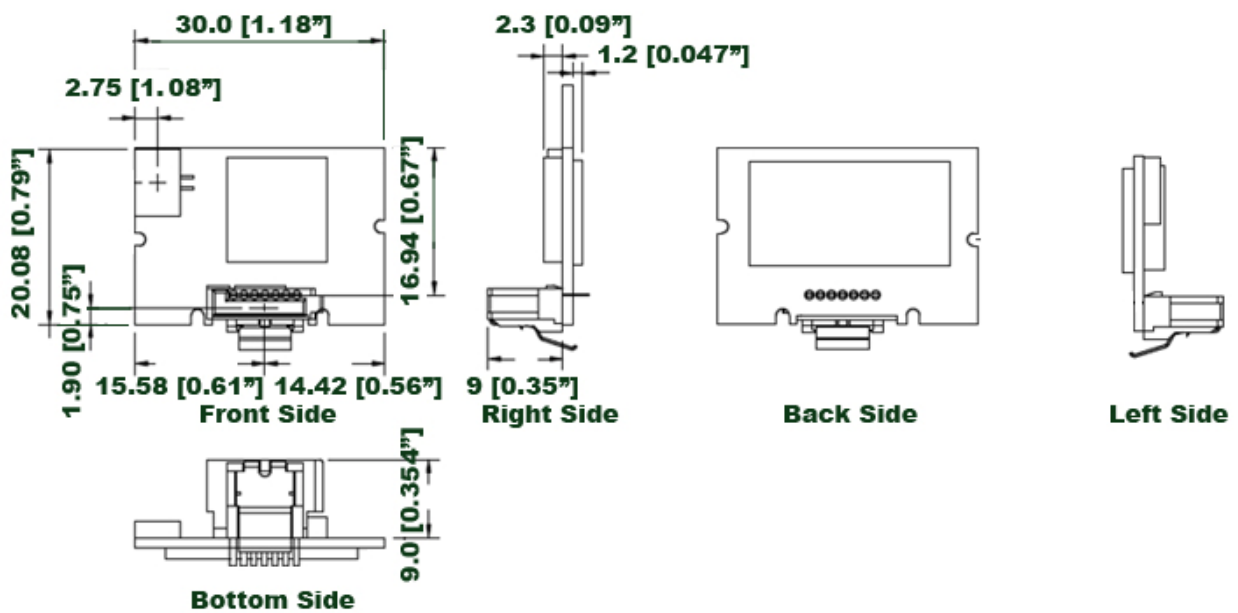

**Horizontal Type - Low Profile w/ mounting hole (HO)**

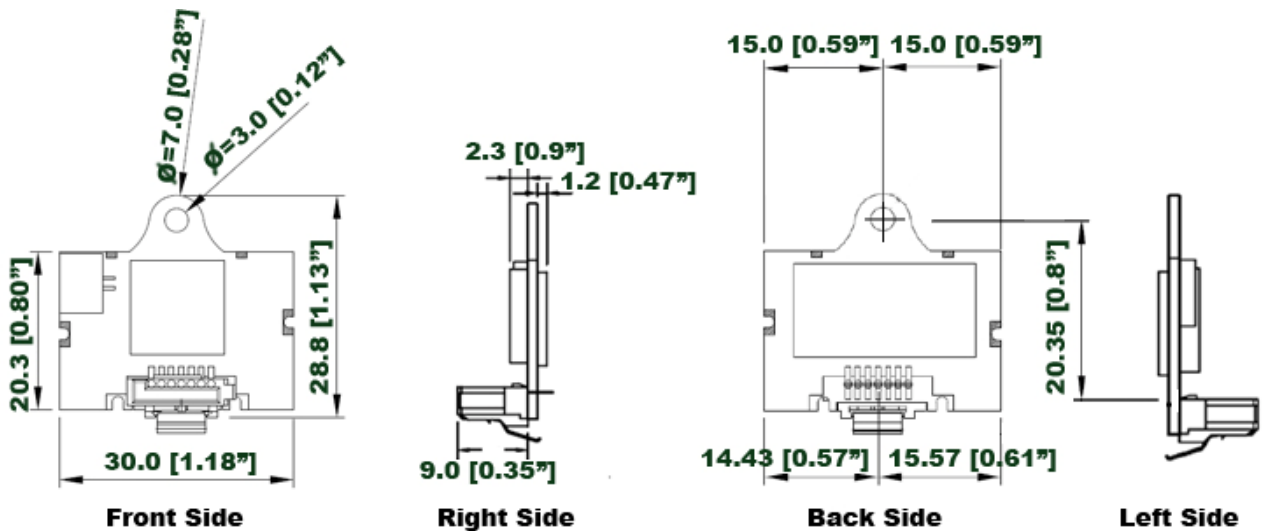

**Figure 6 - Dimension of mSATA Flash Disk**

## 2.6. Capacity Specifications

APRO Industrial mSATA Flash Disk products are built-in mainly Samsung NAND Type SLC Flash memory chips. The Table 7 shows the equipollent part number of applied Samsung Flash memory chips for each card.

**Table 7 - Card Configuration vs. Samsung NAND SLC part number**

Card Capacity	Samsung SLC Flash Memory Part Number * Q'TY
128MB	K9F1G08U0A - PCB0/PIB0 (1Gb) or equipollent * 1
256MB	K9F2G08U0A - PCB0/PIB0 (2Gb) or equipollent * 1
512MB	K9F4G08U0A - PCB0/PIB0 (4Gb) or equipollent * 1
1GB	K9F8G08U0M - PCB0/PIB0 (8Gb) or equipollent * 1
2GB	K9KAG08U0M - PCB0/PIB0 (16Gb) or equipollent *1
4GB	K9WBG08U1M - PCB0/PIB0 (32Gb) or equipollent *1
8GB	K9NCG08U5M - PCB0 (64Gb) or equipollent *1

The table 8 shows the specific capacity for the various models and the default number of heads, sectors/track and cylinders.

**Table 8 - Model Capacity**

Unformatted Capacity	Default Cylinder	Default Head	Default Sector	Default LBA Capacity
128MB	249	16	63	250992
256MB	499	16	63	502992
512MB	999	16	63	1006992
1GB	1950	16	63	1965600
2GB	3900	16	63	3931200
4GB	7801	16	63	7863408
8GB	15603	16	63	15727824

### **3. General Feature Set**

#### **3.1. SATA I Controller**

APRO Industrial mSATA Flash Disk - Aegis series build in SATA 1 controller, it supports Serial ATA Gen.1 (1.5 Gbps), and supports hot-plug. Refer to SATA I controller support one flash IC and communicates with host interface, this SATA I controller supports the flash ICs by 4kbyte/page.

#### **3.2. Wear-Leveling**

APRO Industrial mSATA Flash Disk uses a wear-leveling algorithm to ensure that consecutive writes of a specific sector are not written physically to the same page and block in the flash. This spreads flash media usage evenly across all pages, thereby extending flash lifetime.

Notice that flash memory can be erased within the erase cycle limit or write endurance limit and is defined by the flash array vendor. The erase cycle limit applies to each individual erase block in the flash device.

#### **3.3. Error Detection and Correction**

This SATA controller build in the highly efficiency of **Error Detection and Correction**.

The ECC unit consists of the Parity Unit (parity-byte generation) and the Syndrome Unit (syndrome-byte computation). This unit implements an algorithm that can correct 8 bits per 512 bytes in an ECC block.

#### **3.4. Read Recovery Technology**

Read Recovery Technology enables reliable storage. When it is detected correctable error during read command operation, all data of related block is corrected and is moved to other block. Since it continues to read data after recovery operation, read data is the same as no error data for host system. However, since data transfer is stopped temporarily, the output time of BSY signal becomes long.

In order to perform Read Command Recovery, it is necessary to set up the threshold for the number of detected error bit.

#### **3.5. Auto Power Down Mode**

Auto Power Down is performed as follows in this device.

When the time between the completions of each reset and commands and the next command request is more than threshold which is set by IDLE command, Auto Power Down is performed. Internal state changes active mode to sleep mode.

## 4. Interface Description

### 4.1. Physical Description

APRO Industrial mSATA Flash Disks – Aegis series follow standard SATA 1.0a with 7-pin signal segment. The interface is 7-pin female connector. There are 2 solutions for customer's requirement. If customer's motherboard design in the SATA interface pin-7 with 5V power output, there is one solution which is built-in power pin as the 7<sup>th</sup> pin of 7pin header (w/fuse) , or one solution w/o fuse and for connection via cable, the cable should be no longer than 1meter.

Figure 7 is the aspect of the connector of mSATA Flash Disk.

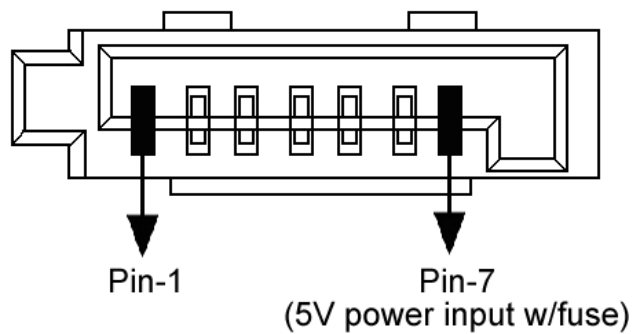

Figure 7 - The front view of mSATA Flash Disk Aegis Series

### 4.2. Pin Assignments

There are total of 7 pins in the signal segment. The pin assignments are listed in below table 9.

Table 9 - Pin Assignments

Pin No.	Signal Name	Description
S1	GND	Shielding
S2	A+	Differential signal to A
S3	A-	Differential signal to A-
S4	GND	Shielding
S5	B-	Differential signal to B
S6	B+	Differential signal to B
S7	GND or VCC (+5V)	Shielding/Power

**Note:**

1. All pins are in a signal row with a 1.27 mm (0.050" pitch).
2. The commands on the mating sequence in forward table apply to the case of backplane blind mate connector only. In this case, the mating sequences are:
  - (1) The pre-charge power pins and other ground pins.
  - (2) The signal pins and the rest of the power pins.

## 5. Electrical Specification

### 5.1. Absolute Maximum Rating

Parameter	Symbol	Rating	Unit
Power Supply Voltage	VDDO	-0.3 ~ +4.5	V
	VDDC	-0.3 ~ +2.5	V
	AVDDH	-0.3 ~ +4.5	V
	AVDDL	-0.3 ~ +2.5	V
Input voltage	VIN	-0.3~VDDO+0.3	V
Out current	IOUT	26 (4mA/8mA buffer)	mA
Storage temperature	TSTG	-55~+125	°C

### 5.2. ATA I/O DC Characteristics

Items	Symbol	Standard Value			Unit	Measurement Condition
		Unit				
		Min	Typ	Max		
Input voltage (TTL level)	V <sub>IH</sub>	2.0	VDDO	VDDO+0.3	V	
	V <sub>IL</sub>	-0.3	0.0	0.8	V	
Schmidt trigger input (TTL level)	V <sub>+</sub>	1.1	-	2.0	V	
	V <sub>-</sub>	0.8	-	1.7	V	
	V <sub>h</sub>	0.3	-	-	V	
Output voltage	V <sub>OH</sub>	2.4	-	-	V	
	V <sub>OL</sub>	-	-	0.4	V	VDDO=3.0V Ioh=4mA or 8mA
Input leak current	I <sub>IL</sub>	-5	-	5	uA	V <sub>i</sub> =0V or VDDO
Output leak current	I <sub>OZ</sub>	-5	-	5	uA	Hi-Z state
Pull-Up resistance	R <sub>U</sub>	10.0	-	100.0	kΩ	V <sub>i</sub> =0V
Pull-Down resistance	R <sub>D</sub>	10.0	-	100.0	kΩ	V <sub>i</sub> =VDDO

## 6. ATA/ATAPI Command List

Command	Code	Support
Check Power Mode	E5H (98H)	YES
Execute Device Diagnostic	90H	YES
Format Track	(50H)	YES
Identify Device	ECH	YES
Idle	E3H (97H)	YES
Idle immediate	E1H (95H)	YES
Initialize Device Parameters	(91H)	YES
NOP	00H	YES
Read Buffer	E4H	YES
Read Long Sector	(22H or 23H)	YES
Read Multiple	C4H	YES
Read Sector(s)	20H or 21H	YES
Read Verify Sector	40H or 41H	YES
Read DMA	C8H	YES
Recalibrate	(1XH)	YES
Seek	70H	YES
Set Features	EFH	YES
Set Multiple Mode	C6H	YES
Set Sleep Mode	E6H (99H)	YES
Standby	E2H (96H)	YES
Standby Immediate	E0H (94H)	YES
Write Buffer	E8H	YES
Write Multiple	C5H	YES
Write Sector	30H	YES
Write DMA	CAH	YES
Write Verify	(3CH)	YES
Security Set Password	F1H	YES
Security Unlock	F2H	YES
Security Erase Prepare	F3H	YES
Security Erase Unit	F4H	YES
Security Freeze Lock	F5H	YES
Security Disable Password	F6H	YES

---

## 6.1. Directions

Please attention in the following.

1. When DMATp primitive is received, that is recognized as R\_IPp primitive.
2. Following is set by SET FEATURES command automatically.
  - Data transfer speed (Support to PIO mode4, Multiword DMA mode2 and Ultra DMA mode2)
  - Enable/Disable of the Device Initiated Power Management
3. Following is set by SET MULTIPLE command automatically.
  - Sector number par DRQ of Multiword DMA
4. Following Identify Information Data is changed during IDENTIFY DEVICE command automatically.
  - word47 [Max Number of sectors (READ/WRITE MULTIPLE)]
  - word76 [Serial ATA capability]
  - word78 [Serial ATA features support]
  - word79 [Serial ATA feature enable]
  - word255 [CRC bit (0x0000 fixed)]
5. If COMMAND=A0h (PACKET command) is received, this product freezes. However, that is reopened by Software Reset. (PACKET command is NOT supported)
6. Tagged Command Queuing (TCQ) and Native Command Queuing (NCQ) are NOT supported.
7. Spread Spectrum Clocking (SSC) is NOT supported.
8. Interoperability
  - HP DC7600 CMT (ICH7) OK
  - DX6120 Micro Tower (ICH6) OK
  - HP DC5150 Micro Tower (ATI SB400) OK
  - HP xw9300 workstation (Nvidia nForce) OK
  - Host with LyCOM PE-103R5 (Sil3132) OK
  - AMD SB600 NG (Need to update BIOS)

## Appendix A. Ordering Information

### 1. APRO Industrial mSATA Flash Disk Part Number

Part number list – Vertical type Standard Form Factor				
Form-factor			micro SATA flash disk	
Grade			Operating temperature supports	
Vertical type	Capacity	Mode	0° C~ 70° C	-40° C~ 85° C
	128MB	Vertical	SPMSF128M-TACSC-VS	WPMSF128M-TAISI-VS
	256MB	Vertical	SPMSF256M-TACSC-VS	WPMSF256M-TAISI-VS
	512MB	Vertical	SPMSF512M-TACSC-VS	WPMSF512M-TAISI-VS
	1GB	Vertical	SPMSF001G-TACSC-VS	WPMSF001G-TAISI-VS
	2GB	Vertical	SPMSF002G-TACSC-VS	WPMSF002G-TAISI-VS
	4GB	Vertical	SPMSF004G-TACSC-VS	WPMSF004G-TAISI-VS
	8GB	Vertical	SPMSF008G-TACSC-VS	NA

Part number list – Vertical type Standard Form Factor				
Form-factor			micro SATA flash disk	
Grade			Operating temperature supports	
Vertical type	Capacity	Mode	0° C~ 70° C	-40° C~ 85° C
	128MB	Vertical	SPMSF128M-TACSC-VL	WPMSF128M-TAISI-VL
	256MB	Vertical	SPMSF256M-TACSC-VL	WPMSF256M-TAISI-VL
	512MB	Vertical	SPMSF512M-TACSC-VL	WPMSF512M-TAISI-VL
	1GB	Vertical	SPMSF001G-TACSC-VL	WPMSF001G-TAISI-VL
	2GB	Vertical	SPMSF002G-TACSC-VL	WPMSF002G-TAISI-VL
	4GB	Vertical	SPMSF004G-TACSC-VL	WPMSF004G-TAISI-VL
	8GB	Vertical	SPMSF008G-TACSC-VL	NA

Part number list – Horizontal type Standard Form Factor				
Form-factor			micro SATA flash disk	
Grade			Operating temperature supports	
Vertical type	Capacity	Mode	0° C~ 70° C	-40° C~ 85° C
	128MB	Horizontal	SBMSF128M-TACSC-HS	WBMSF128M-TAISI-HS
	256MB	Horizontal	SBMSF256M-TACSC-HS	WBMSF256M-TAISI-HS
	512MB	Horizontal	SBMSF512M-TACSC-HS	WBMSF512M-TAISI-HS
	1GB	Horizontal	SBMSF001G-TACSC-HS	WBMSF001G-TAISI-HS
	2GB	Horizontal	SBMSF002G-TACSC-HS	WBMSF002G-TAISI-HS
	4GB	Horizontal	SBMSF004G-TACSC-HS	WBMSF004G-TAISI-HS
	8GB	Horizontal	SBMSF008G-TACSC-HS	NA

<b>Part number list – Horizontal type Low Profile Form Factor</b>				
<b>Form-factor</b>			<b>micro SATA flash disk</b>	
<b>Grade</b>			<b>Operating temperature supports</b>	
<b>Vertical type</b>	<b>Capacity</b>	<b>Mode</b>	<b>0° C~ 70° C</b>	<b>-40° C~ 85° C</b>
	128MB	Horizontal	SBMSF128M-TACSC-HL	WBMSF128M-TAISI-HL
	256MB	Horizontal	SBMSF256M-TACSC-HL	WBMSF256M-TAISI-HL
	512MB	Horizontal	SBMSF512M-TACSC-HL	WBMSF512M-TAISI-HL
	1GB	Horizontal	SBMSF001G-TACSC-HL	WBMSF001G-TAISI-HL
	2GB	Horizontal	SBMSF002G-TACSC-HL	WBMSF002G-TAISI-HL
	4GB	Horizontal	SBMSF004G-TACSC-HL	WBMSF004G-TAISI-HL
	8GB	Horizontal	SBMSF008G-TACSC-HL	NA

<b>Part number list – Horizontal type Low Profile Form Factor with mounting hole</b>				
<b>Form-factor</b>			<b>micro SATA flash disk</b>	
<b>Grade</b>			<b>Operating temperature supports</b>	
<b>Vertical type</b>	<b>Capacity</b>	<b>Mode</b>	<b>0° C~ 70° C</b>	<b>-40° C~ 85° C</b>
	128MB	Horizontal	SBMSF128M-TACSC-HO	WBMSF128M-TAISI- HO
	256MB	Horizontal	SBMSF256M-TACSC- HO	WBMSF256M-TAISI- HO
	512MB	Horizontal	SBMSF512M-TACSC- HO	WBMSF512M-TAISI- HO
	1GB	Horizontal	SBMSF001G-TACSC- HO	WBMSF001G-TAISI- HO
	2GB	Horizontal	SBMSF002G-TACSC- HO	WBMSF002G-TAISI- HO
	4GB	Horizontal	SBMSF004G-TACSC- HO	WBMSF004G-TAISI- HO
	8GB	Horizontal	SBMSF008G-TACSC- HO	NA

## 2. Part Number Decoder

**X1 X2 X3 X4 X5 X6 X7 X8 X9** — **X11 X12 X13 X14 X15** — **Y1 Y2** / **C**

**X1** : Grade

**S** : Standard Grade – operating temp. 0° C ~ 70 ° C

**W** : Industrial Grade – operating temp. -40° C ~ 85 ° C

**X13** : Controller Grade

**C** : Commercial grade

**I** : Industrial grade

**X2** : The material of case

**B** : Bare (without case)

**P** : Plastic case

**X14** : Flash IC

**S** : Samsung SLC-NAND flash IC

**X3 X4 X5** : Product category

**MSF** : micro SATA flash disk (module)

**X15** : Flash IC grade / Type

**C** : Commercial grade

**I** : Industrial grade

**X6 X7 X8 X9** : Capacity

**128M:** 128MB

**256M:** 256MB

**512M:** 512MB

**001G:** 1GB

**002G:** 2GB

**004G:** 4GB

**008G:** 8GB

**Y1 Y2** : MSF orient only

**VS** : Vertical Type Standard form factor

**VL** : Vertical Type Low profile form factor

**HS** : Horizontal Type Standard form factor

**HL** : Horizontal Type Low profile form factor

**HO** : Horizontal Type Low profile form factor with mounting hole

**X11** : Controller

**T** : TDK (Aegis series)

**C** : Reserved for specific requirement

**C** : Conformal-coating

**X12** : Controller version

**A,B,C.....**

---

## ***Appendix B. Limited Warranty***

APRO warrants your Industrial mSATA Flash Disks against defects in material and workmanship for the life of the drive. The warranty is void in the case of misuse, accident, alteration, improper installation, misapplication or the result of unauthorized service or repair. The implied warranties of merchantability and fitness for a particular purpose, and all other warranties, expressed or implied, except as set forth in this warranty, shall not apply to the products delivered. In no event shall APRO be liable for any lost profits, lost savings or other incidental or consequential damages arising out of the use of, or inability to use, this product.

***BEFORE RETURNING PRODUCT, A RETURN MATERIAL AUTHORIZATION (RMA) MUST BE OBTAINED FROM APRO.***

Product shall be returned to APRO with shipping prepaid. If the product fails to conform based on customers' purchasing orders, APRO will reimburse customers for the transportation charges incurred.

---

## **Appendix C. After Service**

### **1. Policy**

In order to return any item for repair, an RMA (Return Merchandise Authorization) number must be assigned by APRO. Customers need to provide the following information, before an RMA will be issued:

- **Product model**
- **Quantity**
- **Lot number**
- **Defect description**
- **Customer name**
- **Contact person**
- **Email address or telephone number**
- **Shipping address**

In order to receive an RMA number, please contact our customer service department via fax or email:

- **Fax the RMA Request Form to 886-2-2929 0389. The RMA Request Form can be downloaded from [http://www.apro-tw.com/supports\\_tl/APRO%20RMAform.pdf](http://www.apro-tw.com/supports_tl/APRO%20RMAform.pdf)**
- **Email to [rma@apro-tw.com.tw](mailto:rma@apro-tw.com.tw)**

The description of the defect needs to be clear and complete in order for APRO to address the problem according to customer expectations. Without a clear description, APRO can only provide a basic test of the returned products.

#### **1.1. Warranty period**

**Commercial Grade    3 years**

**Industrial Grade     5 years**

#### **1.2. Service charge under warranty period**

For a warranty repair, there is no charge.

#### **Remark:**

***The warranty does not cover product damage due to improper operation or force of nature such as fire or flood.***

#### **1.3. Service charge for out of warranty period**

Out of warranty repair charges are dependent on component cost and labor time. APRO will issue an estimate after diagnosing the problem.

#### **1.4. End of Life service**

APRO cannot guarantee repair of any products beyond one year of End-of-UF(-F)ife due to limited availability of replacement components. If repair components are not available, APRO will suggest equivalent products for purchase and offer special pricing.

---

## **1.5. Shipping Charges**

The customer is responsible for packaging the product such that no additional damage occurs during normal shipping and handling. Any freight-collect shipments without notice in advance will be refused.

For warranty repairs, the customer is responsible for the cost of shipping the product back to APRO. APRO will pay for shipping back to the customer.

For DOA warranty replacements, APRO will pay shipping charges for return and replacement. APRO reserves the right to use the most economical shipping method available.

## **2. Procedure**

The definition of defective products fall into three categories as described below:

- RMA in warranty period
- RMA out of the warranty period

The above terms are determined by the purchase date on the invoice up to the time to product is returned to APRO. APRO's repair service procedure is as follows:

### **2.1. Request an RMA Number from APRO:**

- (1) Fill out an "RMA Request Form" and send it by fax to +886-2-2929 0307 or e-mail to [rma@APRO-tw.com](mailto:rma@APRO-tw.com)
- (2) APRO's RMA engineer will check that the "RMA Request Form" has been completed with precise information. Then the customer will receive a RMA number.  
If you need a replacement rather than wait for the returned defective product to be repaired, this requirement must be noted in your "RMA Request Form".

### **2.2. Package and Delivery to APRO**

- (1) Returned products have to be packed properly to avoid damage during the transportation.
- (2) DOA products: DOA products qualify for complete replacement and have to be returned with all accessories included in the original purchase.
- (3) Please indicate your unique RMA number on the top outside of the package.
- (4) To speed up the RMA/DOA procedure, please notify us by e-mail ([rma@APRO-tw.com](mailto:rma@APRO-tw.com)) with information that includes the shipping date, the name of carrier and the tracking number of the package.

### **2.3. Product Check On Arrival**

- (1) APRO's RMA engineer will check your product within 8 hours since arrival.
- (2) If the product arrives undamaged and conforms to the conditions described on the "RMA Request Form", it will be for repairing.
- (3) If the product is damaged or there is some inconsistency with the "RMA Request Form" description, APRO will contact and confirm the status with the customer before proceeding.

### **2.4. Repair**

- (1) The RMA engineer will repair the defect as described by the customer. The products will also be tested to ensure it is in proper working order.

- 
- (2) If no additional problems are detected, APRO will notify the customer.
  - (3) If the customer does not reply us within 48 hours, and no failure occurs during testing, the product will be processed as NTF. (No testing failure).

### **2.5. Charge**

The customer will be charged for repairs under below conditions:

- RMA is out of the warranty period
- RMA or DOA terms apply, but it is determined by APRO's RMA engineer that the defect was caused by abuse, misuse or unauthorized repair.

### **2.6. Package and Delivery to the customer**

- (1) We will properly pack the repaired product along with a RMA report.
- (2) The RMA number and quantity will be clearly marked on the package.
- (3) The customer will receive an e-mail notification of the product RMA number and shipping advice.